

2013 National 4-H Forestry Invitational Handbook

<http://www.4hforestryinvitational.org/>

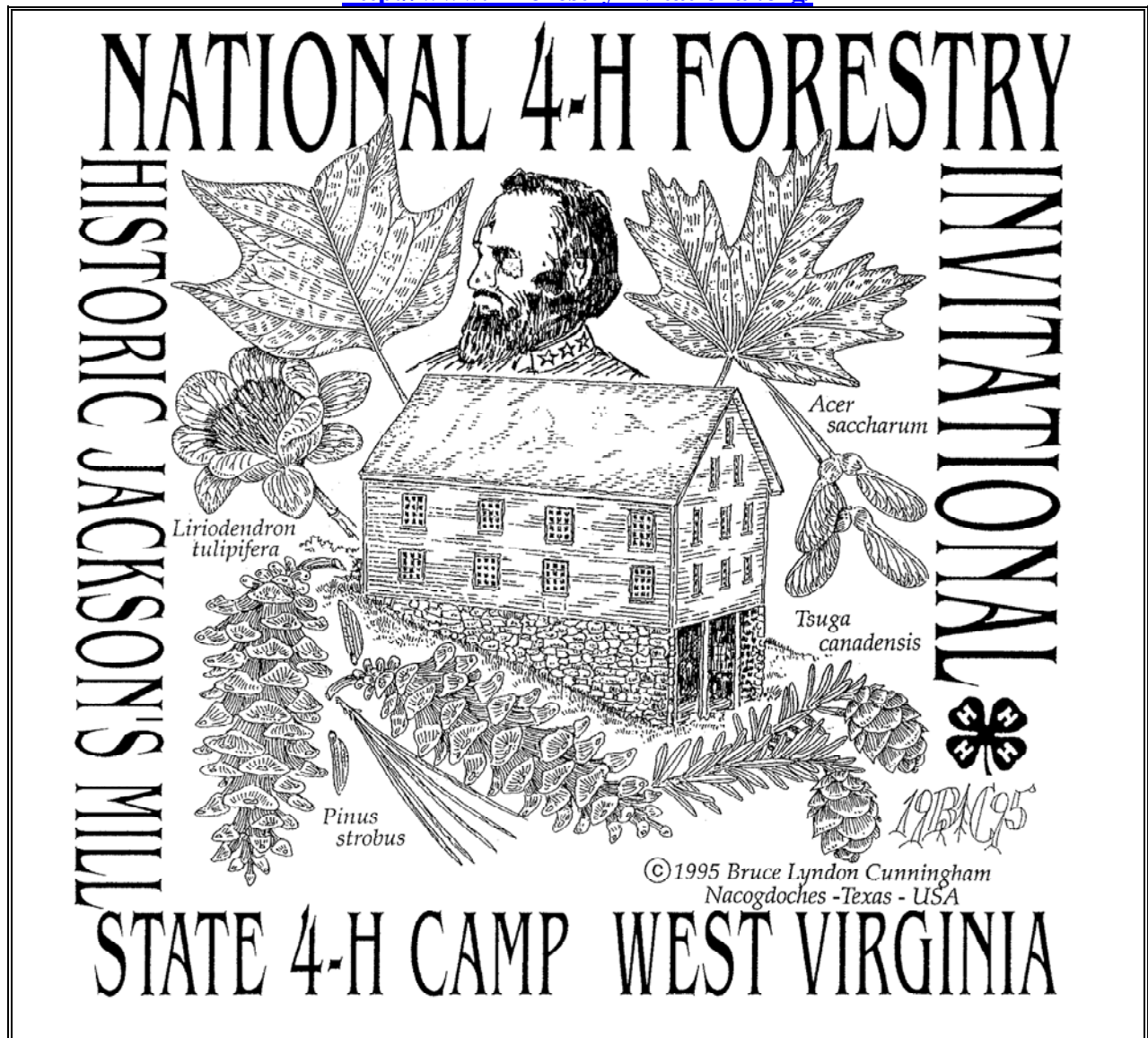

The 2013 National 4-H Forestry Invitational is sponsored by:

Farm Credit System
The Sustainable Forestry Initiative
West Virginia University Extension Service
Society of American Foresters
Association of Natural Resource Extension Professionals
American Forest Foundation

NATIONAL 4-H FORESTRY INVITATIONAL HANDBOOK

CONTENTS

	Page
Introduction	1
Objectives	2
General Rules and Regulations	3
Tree Identification	5
Forest Health -- Insects	9
Forest Health -- Diseases and Health Indicators	12
Tree Measurement	14
Compass and Pacing	19
Topographic Map Contest	22
Forestry Bowl	25
Forest Evaluation	31
Forestry Written Examination	40
Scoring Method for Individual and Team Competition	40
Forest Understandings and Facts	41
Glossary	44
A Summary of Federal Laws Affecting Forestry	48
References	50

This handbook was originally prepared by the National 4-H Forestry Invitational Committee for an experimental event first conducted at the State 4-H Camp, Jackson's Mill, West Virginia, July 1980.

Thirty-second Edition, May 27, 2011

Original Editor, Dr. Frank Roth, now Retired Forester, Arkansas Forestry Commission

The Extension Service, United States Department of Agriculture, offers its programs to all eligible persons regardless of race, color, sex, religion, age, national origin or disability; and is an equal employment opportunity employer.

<http://www.4hforestryinvitational.org/>

NATIONAL 4-H FORESTRY INVITATIONAL MANAGEMENT COMMITTEE

Dave Apsley

Ohio State University Extension
17 Standpipe Road
Jackson, OH 45640-9268
(740)286-5044 ext. 30
FAX (740)286-1578
apsley.1@osu.edu

Sarah Ashton

Program Coordinator
Southern Regional Ext. Forestry
Forestry Bldg 4-420
Athens, GA 30602
(706)542-8908
sashton@sref.info

Sunshine Brosi

Assistant Professor
Frostburg State University
205 Compton Science Center
Frostburg, MD 21532-2303
(301)687-4213
slbrosi@frostburg.edu

Linda Carnell

West Virginia Forestry Division
1 Depot Street
Romney, WV 26757-1400
(304)822-4512
FAX (804)822-7331
Linda.O.Carnell@wv.gov

Todd Dailey

Todd Dailey
Farm Credit of Florida
5075 NW Blichton Road
Ocala, FL 34482
(352) 622-4188
(800) 342-3795
TDailey@FarmCreditFL.com

Amy Fannon-Osborn

Extension Agent
Virginia Cooperative Extension
P. O. Box 1156
Wise, Virginia 24293-1156
(276) 328-6194
FAX (276)328-5902
afannon@vt.edu

Tommy & Susan Futral

Futral Outdoors
11260 Pearson Chapel Rd.
Goodwater, AL 35072
(256)794-1869
futraloutdoors@yahoo.com

Gary Goff

Extension Associate
Department of Natural Resources
Cornell University
104 Fernow Hall
Cornell University
Ithaca, NY 14853
(607)255-2824
grg3@cornell.edu

Bob Hansen

Penn State Extension
701 South Fourth Street
Towanda, PA 18848
(570)265-2896
FAX (570)265-4371
rsh7@psu.edu

William Hubbard

Southern Regional Extension
Forester
The University of Georgia
4-402 Forest Resources Building
Athens, GA 30602
(706)542-7813
Fax: (706)542-5070
whubbard@uga.edu

David Jackson, Chairman

Forest Resources Educator
Penn State Extension
420 Holmes Avenue
Willowbank Building, Room 322
Bellefonte, PA 16823-1488
(814)355-4897
FAX (814)355-6983
drj11@psu.edu

Danielle Martin

Forest Pathologist
State and Private Forestry
USDA Forest Service
Morgantown, WV 26505-3180
(304)285-1531
dkmartin@fs.fed.us

David McGill, Co-chairman

WVU Extension Service/AHC
P.O. Box 6125
Morgantown, WV 26505-6125
(304)293-2941 ext. 2474
FAX (304)293-2441
dmcgill@wvu.edu

Barb McWhorter

Staff Forester
USDA-NRCS
1550 Earl Core Road, Suite 200
Morgantown, WV 26505
(304)284-7576
FAX (304)284-4839
Barbara.McWhorter@
wv.usda.gov

Sheldon Owen

Wildlife Extension Specialist
West Virginia University
329D Percival Hall
PO Box 6125
Morgantown, WV 26506
(304)293-2990
Sheldon.Owen@mail.wvu.edu

Rick Turcotte

Forest Entomologist
USDA Forest Service
180 Canfield Street
Morgantown, WV 26505
(304)285-1505
FAX (304)285-1505
rturcotte@fs.fed.us

Bill Worrell

Natural Resources Extension
Agent
Virginia Cooperative Extension
113 E. Main Street
Lebanon, VA 24266
(276)889-8056
bworrell@vt.edu

FOR REFERENCE:

Jackson's Mill 4-H Conf. Center
Weston, WV 26452
1-800-287-8206
(304)269-5100
FAX (304)269-3409
Jacksons.Mill@mail.wvu.edu

Carol Benesh

National Program Leader
Division of Youth and 4-H
USDA, National Institute of Food
and Agriculture (NIFA)
4405 Waterfront Centre
800 9th St., SW,
Washington, DC 20024
(202)401-6861
FAX (202)720-9366
cbenesh@nifa.usda.gov

Dr. Eric Norland

National Program Leader
Division of Environmental
Systems
USDA, National Institute of Food
and Agriculture (NIFA)
3212 Waterfront Centre
800 9th St., SW,
Washington, DC 20024
(202)401-5971
FAX (202)401-1706
enorland@nifa.usda.gov

(Changes for 2013 are in red see pages 4, 31,34, 38, and 46)

INTRODUCTION

The National 4-H Forestry Invitational is the National Championship of 4-H Forestry. Each year, since 1980, teams of 4-H Foresters from many different states come to Jackson's Mill State 4-H Camp near Weston, West Virginia, to meet, compete and have fun. During two days of competition 4-H Foresters participate in forestry skills and knowledge events including:

- | | |
|----------------------------|---------------------------------|
| 1. Tree Identification | 6. Forest Evaluation |
| 2. Tree Measurements | 7. Insect Identification |
| 3. Compass and Pacing | 8. Disease Identification |
| 4. Topographic Map Contest | 9. Forestry Written Examination |
| 5. Forestry Bowl | |

In addition the Invitational includes recreational activities such as local tours, campfires and lumberjack skills events. Although competitive in nature, the Invitational is managed as an extensive forestry educational experience. It provides an opportunity for exploration of the broad aspects of forestry. The setting, contests, leadership, and supplementary events are all directed to this end.

The event is organized and managed by a national steering committee consisting of Extension Service forestry professionals, county Extension educators, US Forest Service professionals, forestry industry representatives, state forestry agency professionals and other university faculty.

Team Development

There is no standardized national system for team development or the selection of teams to attend the National 4-H Forestry Invitational. Individual state 4-H forestry programs are too diverse for such standardization. Ideally, there should be county, regional, and state competitions with the winners competing on the national level. Realistically, however, team development must be according to in-state structures and resources. We recommend that a system be established in each state for potential team members to become thoroughly familiar with the Invitational events. This might be at regional or state 4-H forestry camps, or as a special addition to more general natural resources camps. This Handbook is intended as a rule book for the National 4-H Forestry Invitational and as a guide for team development. Please ask forestry professionals to assist with team training, and use other educational materials to broaden the 4-H member's understanding of forestry. Such an understanding is essential to success in the Invitational, and to the successful management of our nation's forest resources in the future.

OBJECTIVES

The objectives of the National 4-H Forestry Invitational are to provide the opportunity and atmosphere for 4-H members from all states to:

1. develop leadership talents and to work toward achieving character development and effective citizenship;
2. develop an appreciation of the importance of conserving forests as a sources of income, raw materials, and enjoyment necessary for quality living; and
3. acquire information and understanding of practical forestry skills in forest management and the use of forest and wood products.

In addition to meeting these objectives, the event encourages and promotes increased knowledge of forests and forestry by 4-H members, volunteer leaders, and Extension agents at local, county, district, state, and national levels. Although they may never be forest landowners, as future adults, 4-H members will learn to weigh and understand renewable resource management needs. Preparation of youth for this event: (1) presents, identifies, and locates the renewable resources of the forest environment such as forest products, water, outdoor recreation, wildlife, and selected grazing; (2) establishes a natural resource value system for participating 4-H members; (3) helps 4-H landowners understand the techniques of managing their land and improving the understanding of 4-H'ers as potential landowners; and (4) furnishes facts and scientific procedures for future landowners, administrators, and planners who are not professional land managers.

The Competitive Team Approach, which is used in the National 4-H Forestry Invitational, develops at all levels the following benefits: (1) Intensified learning opportunities using correct management information and factors concerning forest resources; (2) Standardizes, or presents, similar references, materials, guides, and understanding on tree identification, forest measurements, and use of silvicultural problems of management, insects, diseases, etc.; (3) Encourages rural, suburban, and urban teens to share ideas and visit potential management areas with a new perspective of 4-H forestry; (4) Provides new insight to senior members who serve as teen leaders with younger 4-H members in beginning forestry projects; (5) Allows teen members to formulate goals and discuss management procedures with other 4-H'ers and with professional land managers; and (6) Provides a new dimension for older 4-H member activities and incentives for younger members beyond the present project-oriented program.

GENERAL RULES AND REGULATIONS

This event will comply with all "Policies and Guidelines for National 4-H Competitive Events" as approved by USDA Extension Service, 1990.

Contestants and Eligibility

1. Each state is allowed to enter only one team or up to two individual contestants. A team will consist of no less than three and no more than four official entrants who are 4-H members in their state during the current year. If a state is unable to muster a team, it may send up to two contestants to compete in the individual events only.
2. All contestants must have passed their 14th birthday on or before December 31 of the preceding year, and must not have passed their 19th birthday on January 1 of the contest year.
3. An individual may enter the National 4-H Forestry Invitational event only once.
4. The team of contestants must be certified as the official state entry by the State Extension Director or by a person designated by the Director. The individuals or team may be selected by any procedure which a state considers appropriate.
5. Contestants in the National 4-H Forestry Invitational must not have participated in official post secondary (university, college, junior college, or technical school) competitive events of a similar nature in the same subject matter area. Neither can he/she be a member of a post secondary team undergoing training in preparation for an event. (For example, a contestant who has competed in an official collegiate forestry contest, either on or off campus, is ineligible to compete.) The State 4-H Program Leaders are responsible for determining the eligibility for participants in National 4-H Competitive Events from their respective States.
6. All states participating in the Invitational must provide a signed statement from the State 4-H Office verifying that the team has insurance coverage while traveling and attending the Invitational.

General Contest Rules

1. State team entries must be submitted on an official entry blank, by the specified due date.
2. Each team shall have no more than one head coach and two assistant coaches. Current 4-H members may serve as coaches for the team, but those individuals will be ineligible as future contestants.
3. Adult representatives from states not competing in the current Invitational are welcome to observe. They may be asked to assist in the Invitational administration.
4. Only contestants and designated officials shall be within the perimeter of an event other than certain parts of the Forestry Bowl. Once a contestant has started an event, he/she will not be allowed to talk with anyone other than a designated official until completion of that particular event, except in certain team events.

5. A team may be composed of either three or four members. A team captain will be selected by each state for the Invitational contest. Team scores will be based on the **three highest scoring team members in each individual contest area**. Individual contestants will compete for high-scoring individual honors.
6. There are certain activities at the Invitational for which attendance is required. If a team or team member (including the coach) is absent from a required activity, all points earned during that day's competition will be forfeited. If the attendance policy is abused prior to the start of competition, all points for the first day of competition will be forfeited.
7. Each contestant will bring a clip board or writing board, pencil, and calculator. **Binoculars and hand lenses are permitted for use during contest events**. Contestants are encouraged to wear field clothing and heavy shoes. Raingear is highly recommended.
8. **No image or audio recording device such as cell phones, I-pods, still cameras, video cameras, movie cameras, or tape recorders will be permitted during competitive events listed in paragraph 1 of Introduction on page 1. No Invitational participant (4-H team member, coach or adult chaperone) is allowed to write down or record any questions asked during Forestry Bowl competitions or from written exam.**
9. The use of alcoholic, tobacco or other controlled substances will NOT be allowed. Rules of the 4-H camp will be enforced.
10. After the Invitational, individual and team scores will be distributed to the team coach. Contest score sheets will not be distributed.
11. A hard hat will be provided for all 4-H team members, coaches and adult chaperones. Each state delegation will provide its own safety glasses or glasses. Hard hats and safety glasses **must** be worn when a team member, coach or adult chaperone enters a woodland area. Failure to comply with this policy will eliminate the team from competition.
12. Any Invitational participant (4-H team member, coach or adult chaperone) who participates in any of the forestry skills events will be required to wear the personal protection equipment supplied by the Invitational for that event. Closed-toed shoes will be worn by all participants in the forestry skills events. Sandals or other open-toed shoes will not be worn during participation in any of the forestry skills events.

Appeals Procedure

1. The National 4-H Forestry Invitational contest is, primarily, an educational program and few problems should be associated with the competition. However, realizing that the pressure to win is human nature, the Appeals Procedure, as stated in the ECOP Policies and Guidelines for National 4-H Competitive Events will be used.
2. The Invitational Management Committee will serve as the Appeals Committee and review recommendations for operational and procedural changes. Appeals must be filed by the Invitational team captain with the Invitational Chairman within 30 minutes of the end of the day's scheduled contest events and before supper of that day. Forestry Bowl appeals will be handled according to Bowl rules as stated in "Procedures for Protest," page 28.

TREE IDENTIFICATION

Objective

Contestants will learn to recognize and identify different tree species. This skill is valuable because tree species have varying requirements for growth, and differ in use and value.

Contest Rules

1. Each contestant will have the opportunity to identify 25 trees as found in a natural outdoor condition or from branches or other parts displayed, and 25 herbarium specimens of trees found in sections of the United States other than the Invitational site. All trees to be identified will be taken from the "official tree list" below.
2. Contestants will be judged on the accuracy of identification and the spelling of common names. Scientific names will not be required. Incomplete names, such as maple instead of red maple or shortleaf instead of shortleaf pine, will be considered incorrect. **Spelling, including capitalization, must be the same as that on the Official Tree List in order to be counted correct.**
3. Contestants will be given a specific time to identify the tree specimens and record the information on the score sheet.
4. Two points will be given for the correct common name. One-half point will be deducted for each name misspelled. Common names must be those used in the "official tree list." Maximum score for this event is 100 points.

OFFICIAL TREE LIST

Common Name

Scientific Name

Gymnosperms (Softwoods)

Dicotyledons

balsam fir	<i>Abies balsamea</i> Mill.
white fir	<i>Abies concolor</i> Lindl.
noble fir	<i>Abies procera</i> Rehd.
incense-cedar	<i>Calocedrus decurrens</i> Torr.
Rocky Mountain juniper	<i>Juniperus scopulorum</i> Sarg.
eastern redcedar	<i>Juniperus virginiana</i> L.
tamarack or eastern larch	<i>Larix laricina</i> K. Koch.
white spruce	<i>Picea glauca</i> Voss
blue spruce	<i>Picea pungens</i> Engelm.
red spruce	<i>Picea rubens</i> Sarg.
Sitka spruce	<i>Picea sitchensis</i> Carr.
lodgepole pine	<i>Pinus contorta</i> Dougl.
shortleaf pine	<i>Pinus echinata</i> Mill.
pinyon pine	<i>Pinus edulis</i> Engelm.
sugar pine	<i>Pinus lambertiana</i> Dougl.

longleaf pine
ponderosa pine
red pine
pitch pine
eastern white pine
loblolly pine
Virginia pine
Douglas-fir
giant sequoia
redwood
baldcypress or bald cypress
Pacific yew
northern white-cedar or arborvitae
western redcedar
eastern hemlock
western hemlock

Pinus palustris Mill.
Pinus ponderosa Dougl.
Pinus resinosa Ait.
Pinus rigida Mill.
Pinus strobus L.
Pinus taeda L.
Pinus virginiana Mill.
Pseudotsuga menziesii Franco
Sequoia giganteum Lindl.
Sequoia sempervirens Lindl.
Taxodium distichum Rich.
Taxus brevifolia
Thuja occidentalis L.
Thuja plicata Donn.
Tsuga canadensis Carr.
Tsuga heterophylla Raf.

Angiosperms (Broadleaf Trees or Hardwoods)

Dicotyledons

boxelder
Norway maple (exotic invasive)
red maple
silver maple
sugar maple
yellow buckeye
tree-of-heaven (exotic invasive)
red alder
yellow birch
sweet birch or black birch
paper birch
river birch
pignut hickory
pecan
shagbark hickory
mockernut hickory
hackberry
flowering dogwood
common persimmon or persimmon
American beech
white ash
honeylocust
American holly
butternut or white walnut
black walnut
sweetgum
yellow-poplar or tuliptree or tulip-poplar
cucumbertree or cucumber magnolia
southern magnolia

Acer negundo L.
Acer platanoides L.
Acer rubrum L.
Acer saccharinum L.
Acer saccharum Marsh.
Aesculus flava Ait.
Ailanthus altissima (Mill.)Swingle
Alnus rubra Bong.
Betula alleghaniensis Britton
Betula lenta L.
Betula papyrifera Marsh.
Betula nigra L.
Carya glabra Sweet
Carya illinoensis K. Koch.
Carya ovata K. Koch.
Carya alba Nutt.
Celtis occidentalis L.
Cornus florida L.
Diospyros virginiana L.
Fagus grandifolia Ehrh.
Fraxinus americana L.
Gleditsia triacanthos L.
Ilex opaca Ait.
Juglans cinerea L.
Juglans nigra L.
Liquidambar styraciflua L.
Liriodendron tulipifera L.
Magnolia acuminata L.
Magnolia grandiflora L.

red mulberry
black tupelo or blackgum
royal paulownia (exotic invasive)
sycamore or American sycamore
eastern cottonwood
quaking aspen
black cherry
white oak
scarlet oak
southern red oak
water oak
bur oak
northern red oak
black oak
live oak
black locust
black willow
sassafras
American basswood
American elm

Morus rubra L.
Nyssa sylvatica Marsh.
Paulownia tomentosa (Thunb.) Steud.)
Platanus occidentalis L.
Populus deltoides Bartr.
Populus tremuloides Michx.
Prunus serotina Ehrh.
Quercus alba L.
Quercus coccinea Muenchh.
Quercus falcata Michx.
Quercus nigra L.
Quercus macrocarpa Michx.
Quercus rubra L.
Quercus velutina Lam.
Quercus virginiana Mill.
Robinia pseudoacacia L.
Salix nigra Marsh.
Sassafras albidum Nees.
Tilia americana L.
Ulmus americana L.

Monocotyledons

cabbage palmetto or cabbage palm

Sabal palmetto Walt.

This list was cross-referenced and checked for preferred common names, spellings, and scientific names. The following reference was used as the official source for common names, scientific names and spelling:

Little, Elbert L. 1978. Important Trees of the United States. USDA Ag. Handbook 519, 70 pp.

TREE IDENTIFICATION WEB SITE

The Virginia Tech Dendrology web site is a suggested reference for training teams for the Tree Identification Contest. This web site can be accessed from the “Training References” section of the Invitational web site. Individual species listed on the Invitational’s Tree Identification web pages are linked to the Virginia Tech Dendrology web site. Other tree identification web sites are listed for additional help in training.

TREE IDENTIFICATION SCORE SHEET

State	Group No.	Contestant's Name		
No.	Common Name	Correct +2	Misspell -1/2	Score
1				
2				
3				
4				
5				
6				
7				
8				
9				
10				
11				
12				
13				
14				
15				
16				
17				
18				
19				
20				
21				
22				
23				
24				
25				
Contestant's Score				

FOREST HEALTH – INSECTS

Objective

Contestants will learn to recognize and identify forest insects or evidence of insect damage. This is a valuable skill because most insects that damage trees affect only certain tree species or groups of related species. Insect epidemics can cause high dollar value damage in the forests.

Contest Rules

1. Contestants will be required to identify 10 insects or examples of their damage. Specimens will be selected from those on the “Official List of Insects” (page 10).
2. Contestants will be judged on the accuracy of identification and the spelling of the common names. Scientific names will not be required. Incomplete names such as caterpillar instead of eastern tent caterpillar will be considered incorrect. **Spelling, including capitalization, must be the same as that on the Official List of Insects in order to be counted correct.**
3. Contestants will be given a specific time to identify the insect or insect damage specimens.
4. Five points will be given for each correct common name. One point will be deducted for each name misspelled. The common name must be the one used in the "Official List of Insects."

Official Reference for Insects and Diseases

The official reference for the Insect and Disease Identification Contests is the web site link for each insect or disease species listed on the Insect and Disease Identification web pages under the “Training References” section of the Invitational web site.

Additional Reference for Insects and Diseases

The two references listed below are additional references that may be helpful in training for the Insect and Disease Identification contests. However, they are not “Official” references for the Insect and Disease Identification contests.

Insects That Feed on Trees and Shrubs, by Warren T. Johnson and Howard H. Lyon. 1976. Cornell University Press, Sage House, 512 East State St., Ithaca, New York 14850.

Diseases of Trees and Shrubs, by Wayne A. Sinclair, Howard H. Lyon and Warren T. Johnson. 1987. Cornell University Press, Sage House, 512 East State St., Ithaca, New York 14850.

Insect and Disease Web Sites

The Invitational web site provides links to other insect and disease identification web sites as additional training reference aids. These other web sites are not “Official References” for the contest.

OFFICIAL LIST OF INSECTS

Common Name	Scientific Name
Asian longhorned beetle	<i>Anoplophora glabripennis</i> (Motschulsky)
balsam woolly adelgid	<i>Adelges piceae</i> (Ratzeburg)
beech scale	<i>Cryptococcus fagisuga</i> (Lindinger)
bronze birch borer	<i>Agrilus anxius</i> (Gory)
caterpillar hunter beetle	<i>Calosoma sycophanta</i> (Linnaeus)
checkered beetle	<i>Thanasimus dubius</i> (Fabricius)
Douglas-fir tussock moth	<i>Orgyia pseudotsugata</i> (McDunnough)
eastern tent caterpillar	<i>Malacosoma americanum</i> (Fabricius)
emerald ash borer	<i>Agrilus planipennis</i> (Fairmaire)
European pine sawfly	<i>Neodiprion sertifer</i> (Geoffroy)
fall webworm	<i>Hyphantria cunea</i> (Drury)
forest tent caterpillar	<i>Malacosoma disstria</i> (Hubner)
gypsy moth	<i>Lymantria dispar</i> (Linnaeus)
hemlock woolly adelgid	<i>Adelges tsugae</i> (Annand)
Ips engraver beetles	<i>Ips</i> spp.
Japanese beetle	<i>Popillia japonica</i> (Newman)
locust borer	<i>Megacyllene robiniae</i> (Forster)
locust leafminer	<i>Odontota dorsalis</i> (Thunberg)
mountain pine beetle	<i>Dendroctonus ponderosae</i> (Hopkins)
Nantucket pine tip moth	<i>Rhyacionia frustrana</i> (Comstock)
pales weevil	<i>Hylobius pales</i> (Herbst)
periodical cicada	<i>Magicicada septendecim</i> (Linnaeus)
pine needle scale	<i>Chionaspis pinifoliae</i> (Fitch)
red oak borer	<i>Enaphalodes rufulus</i> (Halderman)
redheaded pine sawfly	<i>Neodiprion lecontei</i> (Fitch)
smaller European elm bark beetle	<i>Scolytus multistriatus</i> (Marsham)
southern pine beetle	<i>Dendroctonus frontalis</i> (Zimmermann)
twolined chestnut borer	<i>Agrilus bilineatus</i> (Weber)
white pine weevil	<i>Pissodes strobi</i> (Peck)
whitemarked tussock moth	<i>Orgyia leucostigma</i> (J.E.Smith)

FOREST HEALTH -- INSECTS SCORE SHEET

State	Group Number	Contestant's Name	
No.	Common Name	Correct +5 Misspelled -1	Score
1			
2			
3			
4			
5			
6			
7			
8			
9			
10			
Contestant's Score			

FOREST HEALTH -- DISEASES AND HEALTH INDICATORS

Objective

Contestants will learn to identify forest diseases and other forest health indicators. This is a valuable skill because most diseases that damage trees affect only certain tree species or groups of related species. Diseases can cause high dollar value damage in the forests. Not all indicators of forest health are diseases. Specimens will be selected and displayed which are representative of diseases and damage.

Contest Rules

1. Contestants will be required to identify 10 diseases, specimens of disease damage or other forest health indicators. Specimens will be selected from those on the "Official List of Diseases and Forest Health Indicators."
2. Contestants will be judged on the accuracy of identification and the spelling of the common names. Scientific names will not be required. Incomplete names will be considered incorrect. **Spelling, including capitalization, must be the same as that on the Official List in order to be counted correct.**
3. Contestants will be given a specific time to identify the disease or damage specimens.
4. Five points will be given for each correct common name. One point will be deducted for each name misspelled. The common name must be the one used in the "Official List of Diseases."

OFFICIAL LIST OF DISEASES AND HEALTH INDICATORS

Common Name	Scientific Name
artist's conk	<i>Ganoderma applanatum</i>
annosum root disease	<i>Heterobasidion annosum</i>
beech bark disease	<i>Neonectria ditissima</i>
black knot	<i>Apiosporina morbosa</i>
brown spot needle blight	<i>Mycosphaerella dearnessii</i>
cedar-apple rust	<i>Gymnosporangium juniperi-virginianae</i>
chestnut blight	<i>Cryphonectria parasitica</i>
dogwood anthracnose	<i>Discula destructiva</i>
Dutch elm disease	<i>Ophiostoma ulmi</i>
dwarf mistletoes	<i>Arceuthobium sp.</i>
fusiform rust	<i>Cronartium quercuum</i> f.sp. <i>fusiforme</i>
hypoxylon canker	<i>Biscogniauxia atropunctata atropunctata</i>
lichens	numerous species
nectria canker	<i>Neonectria ditissima</i>
needle cast fungi	numerous species
oak wilt	<i>Ceratocystis fagacearum</i>
red heart of pine	<i>Phellinus pini</i>
white pine blister rust	<i>Cronartium ribicola</i>
clinker polypore	<i>Inonotus obliquus</i>

Descriptions of these diseases appear in the references cited on page 9.

FOREST HEALTH -- DISEASES & HEALTH INDICATORS SCORE SHEET

State	Group Number	Contestant's Name	
No.	Common Name	Correct +5 Misspelled -1	Score
1			
2			
3			
4			
5			
6			
7			
8			
9			
10			
Contestant's Score			

TREE MEASUREMENT

Objective

Contestants will learn to measure standing trees in order to estimate the volume of forest products that may be obtained from the trees. Since most timber is bought and sold on a volume basis (usually by board foot volume), it is a good idea to have some estimate of total tree volume, volume per acre and volume by product before selling timber.

Contest Rules

1. Any standard tree scale stick may be used. Scale sticks may be purchased from companies such as Forestry Suppliers, Inc., Box 8397, Jackson, MS 39204; Ben Meadows Co., P.O. Box 80549, Atlanta, GA 30366; or TSI Co., Box 206, Flander, NJ 07936.
2. A fixed radius plot will be selected and designated for use in this event. Contestants will be required to give the total volume of sawtimber per acre as determined from the sample plot volume. The plot may be 1/10 acre (37.3 ft radius), 1/5 acre (52.7 ft radius) or 1/4 acre (58.9 ft radius).
3. Contestants will identify 15 trees and estimate their diameters, merchantable heights, and volumes. All values will be recorded. **Please note** - For purposes of this contest tree diameters will be measured and recorded in even 2-inch diameter classes. Tree heights will be measured in 16-foot logs to the nearest full half-log. The smallest tree will be 10 inches DBH (diameter at breast height) and one log merchantable height. Merchantable height will be measured from stump height to an 8-inch top diameter, a major fork or serious defect (hollow or point of decay) which affects greater than half the tree's diameter at that point.
4. Tree volumes will be found in the International 1/4-inch volume table furnished at the contest site (see page 17). **Do not use the volume table on the tree scale stick.**
5. One point will be awarded for each correct tree identification, two points for each correct DBH, and two points for each correct tree height, for a possible total of 75 points. No points will be awarded for individual tree volumes.
6. After all 15 trees have been measured, contestants will determine the total volume in the plot and the volume per acre. Twenty-five points will be allowed for the correct **volume per acre**. Remember, the total volume in the plot must be multiplied by a factor (10 for a 1/10-acre plot, 5 for a 1/5-acre plot and 4 for a 1/4-acre plot) to determine the volume per acre. Point allocation will be 25 for $\pm 5\%$ of the official volume, 20 points for $\pm 10\%$, 15 points for $\pm 15\%$, and no points over $\pm 15\%$.

Example: If 4,000 bd. ft. is the official volume per acre, then an answer between 3800 bd. ft. and 4200 receives 25 points; 3600 to 3799 and 4201 to 4400 receives 20 points; 3400 to 3599 and 4401 to 4600 receives 15 points; and under 3400 and over 4600 receives no points.
7. Maximum score for this event is 100 points.

MEASUREMENT OF STANDING TREES STUDY GUIDE

When trees are sold as harvested products (sawlogs, veneer logs, or pulpwood), the sale is generally based upon a measured volume. The two measurements used to estimate the volume of a tree are diameter and height. Diameter of standing trees is measured by a time-honored custom, at 4-1/2 feet above ground on the uphill side of the tree (if the tree is on a slope). This is abbreviated as **DBH** (diameter breast height). **Height** of a standing tree might be measured as **total** (the entire height from ground line to the top) or **merchantable**. Merchantable height implies the ability to cut lumber, veneer, or other products from the logs. It is the distance from the stump height to the top of the merchantable material in the tree and varies depending on the products to be made from the tree. The basic unit of height measurement for sawtimber is the log, which is 16 feet in length.

To measure diameter, foresters may use a caliper, diameter tape, or tree scale stick. Since the tree scale stick is to be used in the contest, the method of using it will be explained.

The drawing below shows how the tree scale stick is used to find tree diameter. Use the flat side of the stick, which reads, "Diameter of Tree (in inches)." The instrument on this side of the tree scale stick is called a **Biltmore Stick**. Hold the stick against the tree, perpendicular to the trunk, 25 inches from your eye at a height of 4 1/2 feet above ground on the uphill side of the tree. Once the stick is placed against the tree, close one eye and line up the left end with the edge of the tree's bark. Now, **WITHOUT MOVING YOUR HEAD**, look across the stick to the right hand edge of the tree and read the diameter measurement at the point of intersection. Record the measurement by its proper even 2-inch diameter class. For example; if the tree measures between 15.0 and 16.9 inches it should be recorded as a 16 inch diameter tree.

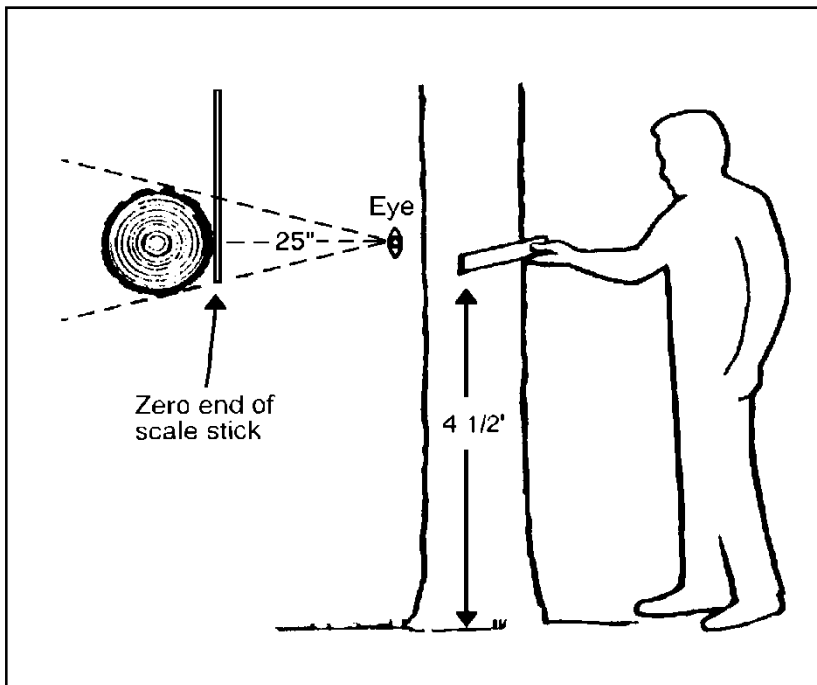

Even 2-inch Diameter Classes

<u>If Diameter Measures</u>	<u>Record As</u>
9.0 - 10.9	10
11.0 - 12.9	12
13.0 - 14.9	14
15.0 - 16.9	16
17.0 - 18.9	18
19.0 - 20.9	20
etc.	

Figure 1. Use of tree scale stick to estimate tree diameter 4 1/2 feet above ground.

To measure height, foresters may use a clinometer, laser hypsometer, relaskop, or tree scale stick. Since the tree scale stick is to be used in the contest, the method of using it is explained below.

To measure the merchantable height of a tree, pace out 66 feet from the base of the tree, to a point where the entire tree can be seen. It is a good idea to stay on the same contour as the tree or slightly up hill from it. Hold the tree scale stick so that the edge of the stick that reads "Number of 16 foot logs" faces you. The instrument on this edge of the tree scale stick is called a **Merritt Hypsometer**. The zero end should point toward the ground. Plumb the stick, at 25 inches from the eye. Sight the zero end to appear to rest at stump height. Stump height, for purposes of this contest, will be measured from one foot above the ground. **DO NOT MOVE YOUR HEAD OR THE STICK.** Look up the stick to a point where the top of the last merchantable cut would be made in the tree (8-inch top diameter, a major fork, or serious defect which affects greater than half the tree's diameter at that point). Read the merchantable height to the nearest **full** half-log. For example, if the merchantable height is slightly more than 2 ½ logs you can record it as 2 ½ logs. But, if the merchantable height is slightly less than 2 ½ logs you must record it as 2 logs.

Practice on pacing is needed to find the 66-foot distance from the tree. The 25-inch distance from your eye to the stick is still the same as in measuring tree diameter.

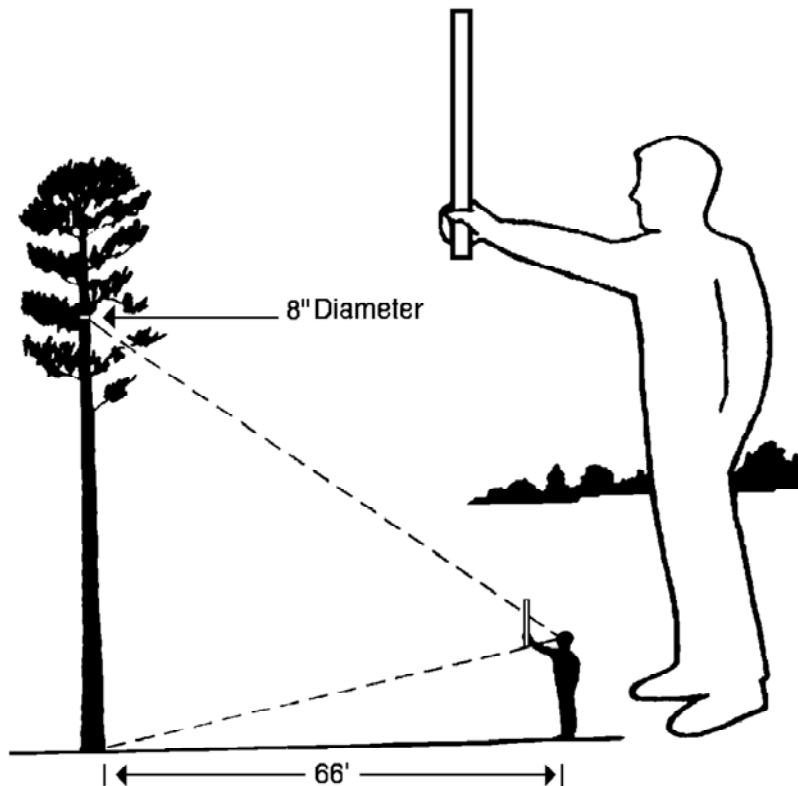

Figure 2. Use of tree scale stick to estimate merchantable height.

VOLUME TABLE

To use this table, first measure the diameter at breast height (DBH) of a tree and place it into the proper even 2-inch diameter class (see page 15). Next measure the merchantable height of the tree in 16-foot logs to the nearest full half log. Read down the left hand column until you come to the row containing the DBH. Then, move across from left to right until you come to the column containing the tree merchantable height at the top. At the intersection of that row and column you will find the merchantable volume of the tree. Read and record each tree volume directly and separately. **FOR CONTEST PURPOSES, DO NOT USE THE VOLUME TABLE ON THE TREE SCALE STICK.**

International ¼ inch Log Rule -- Form Class 78

VOLUME (board feet) BY NUMBER OF 16-FOOT LOGS

DBH	1	1½	2	2½	3	3½	4	4½	5
10	36	48	59	66	73	-----	-----	-----	-----
12	56	74	92	106	120	128	137	-----	-----
14	78	105	132	153	174	187	200	-----	-----
16	106	143	180	210	241	263	285	-----	-----
18	136	184	233	274	314	344	374	-----	-----
20	171	234	296	348	401	440	480	511	542
22	211	290	368	434	500	552	603	647	691
24	251	346	441	523	605	664	723	782	840
26	299	414	528	626	725	801	877	949	1,021
28	347	482	616	733	850	938	1,027	1,114	1,201
30	403	560	718	854	991	1,094	1,198	1,306	1,415
32	462	644	826	988	1,149	1,274	1,400	1,518	1,637
34	521	728	934	1,119	1,304	1,447	1,590	1,727	1,864
36	589	826	1,063	1,274	1,485	1,650	1,814	1,974	2,135
38	656	921	1,186	1,428	1,670	1,854	2,038	2,224	2,410
40	731	1,030	1,329	1,598	1,868	2,081	2,294	2,494	2,693

TREE MEASUREMENT SCORE SHEET

State	Group No.	Contestant's Name			
No.	Species (1 point)	DBH (2 pts)	Height 16 ft logs (2 pts)	Volume Board Feet	Score
1					
2					
3					
4					
5					
6					
7					
8					
9					
10					
11					
12					
13					
14					
15					
	Total board foot volume in plot				
	Total board foot volume per acre				
(a) Subtotal of Tree Scores (75 points possible)					
(b) Score for Volume Per Acre (25 points possible)					
Contestant Score (a + b)					

Plot Size _____

COMPASS AND PACING

Objective

Contestants will learn to estimate ground distances by using the pacing method and to determine direction of travel using a compass. This will be accomplished by measuring a course of five lines. The lines may be level, or slope up or down hill. Successive lines may or may not be continuous.

Contest Rules

1. Each contestant should determine the number of paces he or she takes per 100 feet on a practice course prior to the contest. Pacing distances **must** be estimated using a normal walking stride. **No heel to toe or other measurement is allowed.**
2. A Silva Ranger mirror-sighting type azimuth or quadrant compass will be used during the contest. A hand-held compass of each type will be provided at the starting corner of each line. A contestant may use his or her own hand-held compass, provided that it is of a type that is neither more accurate nor more sophisticated than a Silva Ranger compass. Compass declination should be set at zero.
3. Contestants using a quadrant compass are required to use the correct two-letter designation with each bearing recorded on the score sheet, for example N 27° W.
4. The course layout will consist of five (5) lines with staked corners. Every effort will be made to avoid slopes over 15 percent, steep ravines, heavy brush, large rocks and wetlands on the contest course.
5. Instructions will be given to the contestants before beginning the course. The exercise will be completed on an individual basis. Each contestant will measure the azimuth or bearing and the distance for each line, record the measurements on a score sheet, and return the score sheet to the official in charge.
6. Contestants may receive a maximum total score of 100 points. A maximum of 20 points is possible for each of the five lines, 10 points for the correct azimuth or bearing and 10 points for the correct distance. One-half point will be deducted for each degree of error in the azimuth or bearing up to a maximum of 10 points per line. One-half point will be deducted for each foot of error in distance up to a maximum of 10 points per line.

COMPASS AND PACING STUDY GUIDE

Foresters are often required to estimate horizontal distances by the pacing method, and to determine direction of travel by using a compass. These methods are very useful in cruising timber and finding property boundaries.

All maps and land surveys express the distance between two points as the horizontal distance, that is the distance measured on the level. Thus it becomes necessary to correct for slope when estimating horizontal distance on the ground. Pacing is an expedient, but crude, method of determining ground distances. A pace is two steps (Figure 3). On level, open ground, pacing can become fairly accurate with practice. But, on slopes, and in brushy or rocky areas, its accuracy diminishes (Figure 4). To correct for slope the following suggestions from the *Forestry Handbook* are provided:

In difficult terrain no attempt should be made to maintain a standard pace. Instead, allow for its inevitable shortening (downhill as well as uphill) by repeating the count at intervals. For example, on moderate slopes count every tenth pace twice: 1,2,3,4,5,6,7,8,9,10,10,11,etc. On steeper slopes it may be found necessary to repeat every fifth count: 1,2,3,4,5,5,6,etc. On the steepest slopes in very heavy brush, in swamps, or among boulders, every count may have to be repeated. Consistent accuracy in pacing under such conditions is attained only by practice and is maintained only by constant checking. (*Forestry Handbook*, 1955. Page 17-1.)

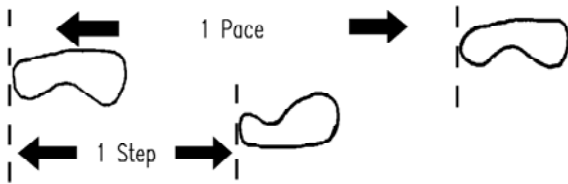

Figure 3. Illustration showing the difference between a step and a pace.

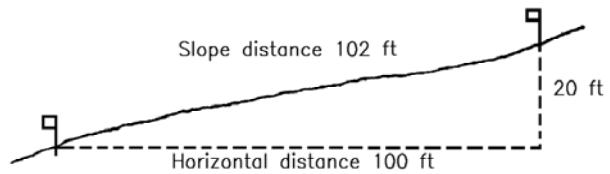

Figure 4. Estimating horizontal distance on a 20 percent slope.

A compass is used to tell the direction of travel by estimating the angle of deflection from magnetic north. Magnetic north is the direction toward which the compass needle always points. Most compasses are designed to measure direction in either azimuths or bearings. Azimuths range from 0° to 360° (Figure 5). Bearings range from 0° to 90° in each of four quadrants (Figure 6).

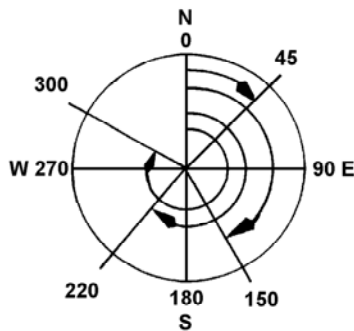

Figure 5. Azimuths are read from an azimuth compass

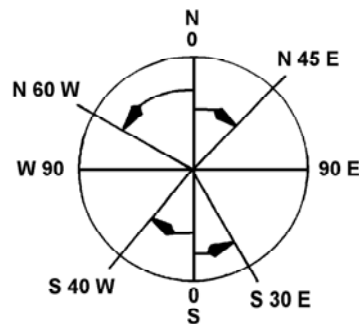

Figure 6. Bearings are read from a quadrant compass

COMPASS AND PACING SCORE SHEET

State		Group No.	Contestant's Name		
Line	Azimuth or Bearing	Points	Distance	Points	Score
A-B					
B-C					
C-D					
D-E					
E-F					
Contestant Score					

Contestants should fill in the azimuth or bearing and distance for each line.

TOPOGRAPHIC MAP CONTEST

Objective

Contestants will learn the following in this contest event:

1. How to identify different features on a topographic map by their symbols
2. How to determine the length of a line established between two points on the map
3. How to determine the bearing (line of travel) between the two points on the map using a mirror-sighting type azimuth compass
4. How to correct the bearing of a line for declination
5. How to determine the change in elevation between two points on the map

Topographic maps are frequently used in forestry as a tool for inventory and management of natural resources. It is important to be able to measure distances, locate property boundaries, and recognize natural and man-made features on these maps. Invitational contestants will learn how to apply their compass and pacing training in conjunction with the use of a 7.5 Minute Series topographic map. The scale on a 7.5 Minute Series map is 1:24,000. This means 1 inch on the map equals 24,000 inches or 2000 feet of actual distance on the ground.

Contest Rules

1. The topographic map contest committee will provide mirror-sighting type azimuth compasses for this event. Contestants will **not** be permitted to use their own mirror-sighting type azimuth compasses. (use of a calculator is permitted)
2. The contest committee will also provide the following equipment for the contest event:
 - a. 7.5 Minute Series Map (same map for all contestants)
 - b. Rulers calibrated in tenths of an inch
3. The map used in the contest will have 10 symbols and/or features identified on it with labeled arrows pointing to the map symbol or feature that needs identifying.
4. Contestants will have to identify 10 map symbols and features from the following list of 30 topographic map symbols and features. Each map symbol or feature is worth three (3) points for a total of thirty (30) points. Answers should be spelled correctly and multi-word answers should be in the same order as specified below. One point will be deducted from answers with these errors.

ridge	valley	peak
saddle	depression	open area
wooded area	marsh	perennial stream
intermittent stream	index contour line	intermediate contour line
primary road	unimproved road	trail
bridge	inhabited building	uninhabited building
school	church	cemetery
campground	quarry	spring
mine tunnel	tank	gravel pit
railroad – single track	railroad – multiple track	power line

To train for this part of the contest, contestants should study the official training reference material on the Invitational's web site. The web address for this part of the contest event is:

<http://4hforestryinvitational.org/training/topographic-map-contest/map-symbols>

5. Contestants will measure the distance between the two points with a ruler calibrated in tenths. Using the "feet" scale at the bottom of the contest topographic map, the contestants will convert the measured distance on the map to the nearest 100-foot denomination, i.e., 900, 1,000, 1,100, 2,300, etc. To train for this part of the contest, contestants should study the official training reference material on the Invitational's web site. The web address for this part of the contest event is:

<http://4hforestryinvitational.org/training/topographic-map-contest/length-of-a-line>

This measurement is worth 5 points, if answered correctly. There will be no partial credit for "close" answers.

6. Contestants will determine the bearing (line of travel) between two points identified on the contest map using a mirror-sighting type azimuth compass provided by contest management personnel at the site. To train for this part of the contest, contestants should study the official training reference material on the Invitational's web site. The web address for this part of the contest event is:

<http://4hforestryinvitational.org/training/topographic-map-contest/bearing-of-a-line>

This bearing is worth 5 points, if within plus or minus 2 degrees of accurate bearing.

7. Contestants will correct the bearing for declination. To train for this part of the contest, contestants should study the official training reference material on the Invitational's web site. The web address for this part of the contest event is:

<http://4hforestryinvitational.org/training/topographic-map-contest/declination>

This corrected bearing is worth 5 points, if calculated correctly.

8. Contestants will determine the difference in elevation between two points identified on the contest map. Using the contour interval provided on the map, contestants will determine the elevation of two different points and then calculate the difference in elevation between them. For example, if point A is at 920 feet and point B is at 1260 feet, the change in elevation is 340 feet.

This calculation is worth 5 points, if answered correctly. There will be no partial credit for "close" answers.

9. Instructions will be given to the contestants before beginning the contest. The exercise will be completed on an individual basis.
10. A maximum of 50 points is possible for this contest event.

Topographic Map Score Sheet

State	Group	Contestant's Name	
	Map Symbol or Feature	Correct +3 Misspelled -1	Score
A			
B			
C			
D			
E			
F			
G			
H			
I			
J			
		Correct +5	
Distance			
Bearing			
Corrected Bearing			
Elevation Change			
Contestant's Score			

FORESTRY BOWL

OBJECTIVES

The Forestry Bowl will provide an opportunity for teams of three or four contestants to demonstrate their knowledge of forestry and related subject matter in a competitive setting where attitudes of friendliness, fairness, and excitement prevail. States **must** have at least three contestants to participate in the Forestry Bowl.

Teams will be placed in a bracket for the Forestry Bowl based on team scores in the written exam. Any byes necessary will be used during the first round of the Forestry Bowl. This will produce a full bracket in the second round.

EQUIPMENT

Panels -- Two interconnecting panels, each to accommodate four contestants plus a moderator panel with suitable controls are to be used. The equipment will be checked prior to the start of each round of competition.

Time keeping device -- A stop watch or other appropriate device is to be used.

Score keeping device -- This may be a blackboard or flip chart.

Questions -- A packet of questions for each round shall be prepared in advance. Each packet shall contain at least 30 questions but not more than 50. If there are several acceptable answers to a question, all answers shall be listed. For the semifinal and final rounds questions may include a visual aid such as a color slide.

Setup -- See diagram on page 30 for a sample bowl contest setup.

OFFICIALS

Moderator (Quiz Master) -- The moderator assumes complete direction of all rounds, asks all questions, designates contestants to answer questions, accepts or rejects all answers, but may seek interpretation of questions.

Referee Judges -- One judge may be used. The referee judge and the moderator must agree on the acceptability or rejection of a question and/or answer if either is challenged by team captains (See Procedure for Protest 1., page 28).

Time-keeper -- A time-keeper will be used to indicate to the moderator the expiration of the time allowed in which to answer questions. The time-keeper may be one of the referee judges but, only when so designated.

Score-keepers -- One or two individuals will keep score on each round. Score-keepers will keep score in such a manner that all points awarded or taken away in penalties may be checked. A judge may serve as score-keeper.

PROCEDURE OF PLAY

Starting the Contest

1. Teams are assembled and seated at their respective panels.
2. The team captains shall be seated nearest the moderator.
3. The question packet is opened by the moderator.
4. The moderator will **not** give the correct answers, except in the final round. No discussion is permitted.

Part I – Directed Questions

5. A coin is tossed to determine which team captain will answer the first question.
6. The second question will be answered by the captain of the opposing team. Succeeding questions will be asked alternately of each team, and rotated among team members, until a total of 24 questions has been asked.
7. Only the designated team member may answer the question. The team member has ten (10) seconds to **begin** the answer, and ten (10) seconds in which to **complete** the answer. A request to repeat the question **must** be made within five (5) seconds, and the question will be repeated only once.
8. If the answer is correct, 10 points will be awarded the team. No points will be given for partial or incorrect answers.

Part 2 – Toss Up Questions

9. Part 2 begins with the moderator reading a toss-up question (as with all succeeding questions) until a contestant activates a buzzer.
 - a. If a buzzer is activated during the reading of any question, the moderator immediately will cease reading the question and the contestant activating the buzzer shall begin the answer based on that portion of the question read.
 - b. If the answer given is incorrect, or no answer is given, **five (5) points are taken from that team's score** and the moderator repeats the question. The opposing team then has ten (10) seconds for any member to activate the buzzer and answer the question. If the answer is incorrect, 5 points will be taken from that team's score. No team consultation is permitted.
 - c. If a bonus question is attached to an incorrectly answered toss-up or a toss-up question is unanswered following an activated buzzer, that bonus question is transferred to the next possible toss-up question to which no bonus question is attached.

10. At the completion of the reading of a question or when a buzzer is activated, ten (10) seconds are allowed in which to begin an answer, and another ten (10) seconds are allowed in which to complete the answer. A request to repeat the question **must** be made within five (5) seconds, and the question will be repeated only once.
11. The answer **must** be given by the contestant activating the buzzer. No consultation on toss-up questions is permitted. It shall be the responsibility of the moderator to determine if an actual answer is started and completed within the time period.
12. If the time in which to answer a question elapses without a contestant activating the buzzer, the question is discarded. If a bonus question was attached to an unanswered toss-up question, the bonus question is then transferred to the next toss-up question to which no bonus is attached.
13. If the toss-up question is correctly answered within the 10-second time limit, that team scores 5 points.
 - a. If a bonus question is attached to the correctly answered toss-up question, the moderator then reads the bonus question and a 10-second discussion period is permitted for the team consultation to determine the answer. The end of the 10-second period is signaled by the timer. At the signal from the timer, a 10-second period is then permitted for the team captain or designee to begin the answer.
 - b. Successful completion of the answer will result in that team being awarded 10 points for that bonus question.
 - c. All parts of the bonus questions must be answered correctly with no partial points permitted regardless of the number of parts of the question answered correctly.
 - d. Failure to answer a bonus question or failure to answer correctly, results in no penalty (loss of points) to the team.

Completing the Contest

1. The moderator will continue reading toss-up and bonus questions until all toss-up questions and their accompanying bonus questions have been asked or 30 minutes have elapsed, whichever comes first, except the last round which may last 45 minutes or less.
2. Following the final question, the scores of the two score keepers shall be compared. If there is disagreement as to the score of the game, the score that is tabulated on the written score card will be used.

PROCEDURE FOR PROTEST

1. Only one protest can be made per team for any one round. Each Bowl game will consist of two (2) rounds: Directed Questions and Toss Up Questions
2. Any protest of a question or procedure **must** be made by the team captain at the time a particular question is presented or is being administered. Once a new question has been read it is too late to protest a previous question.
3. The captain can declare a protest immediately after:
 - a. The question has been read
 - b. The answer has been determined correct or incorrect by the moderator or judge
 - c. Points are awarded
 - d. The moderator gives the correct answer.
4. Upon declaring a protest, the team captain must state on what grounds the question is being protested. The moderator will then rule upon the protest, or consult with the judge and then give their ruling. Options regarding the ruling include:
 - a. The question is discarded and another question is substituted
 - b. The moderator (or judge) agrees or disagrees with the basis of the protest and awards points or not accordingly
 - c. The question may be forwarded to the opposing team in accordance with the contest rules.

It will be the moderator's prerogative to give the correct answer and reason for the ruling before moving on to the next question.

5. Spectators, coaches, parents and visitors may not protest any question, answer, or procedure during the course of play. However, coaches may submit in writing to the contest officials any suggestions, complaints, or protests at the conclusion of the contest. Questions and procedures will then be modified or not as appropriate for future rounds.
6. Inappropriate behavior, unsportsmanlike conduct, or any actions which are generally deemed as detrimental to the contest, may result in dismissal of individual(s) responsible for such actions from the immediate area of the contest. Such action could result in that team's disqualification.

RECORDERS AND CAMERAS

Tape recorders may **not** be used at any time during the conducting of a match. Recording devices such as video tape cameras, movie cameras or any other type of camera requiring auxiliary lights may **not** be used during the conducting of the match. Photographs will be permitted only before or after a match and then only in such a manner as not to be disruptive of the contest.

EQUIPMENT FAILURE

1. If the device being used ceases to function during a match or is believed to be malfunctioning, a "time-out" may be called by any contestant or moderator.
2. If, after checking, it is determined that there is an equipment malfunction, the faulty part or parts will be replaced and play will be resumed.

3. Scores accumulated up to the point of the "time-out" shall stand, and all further points given or taken during the remainder of the match will be added to or subtracted from this total.
4. If both referee judges or one referee judge and the moderator deem it advisable, points awarded for the two (2) questions asked immediately prior to determination of equipment failure may be recalled and two (2) additional questions used.
5. Under no conditions shall there be a replay of a match in which there was equipment failure.

METHOD OF SELECTING FORESTRY BOWL QUESTIONS

Questions will be selected by the National 4-H Forestry Invitational Committee, and all questions used during a particular round will be eliminated for all remaining rounds.

SAMPLE QUESTIONS FOR BOWL

1. A board foot is equivalent to a board that measures: **Answer** -- 12" wide, 1" thick, 12" long, or 144 cubic inches.
2. The board foot formula is: **Answer** -- Length in feet x width in inches x thickness in inches divided by 12.
3. Diameter at breast height (DBH) is measured on the tree trunk at what distance above the average ground level? **Answer** -- 4.5 feet
4. A standard cord of wood is measured: **Answer** -- 4' x 4' x 8' (128 cubic feet)
5. Habitat is: **Answer** -- The area where a plant or animal lives.

REFERENCES FOR FORESTRY BOWL AND WRITTEN EXAM

1. National 4-H Forestry Manuals - Units A, B, and C; available from the "Training References" section of the Invitational web site.
2. *Forests and Forestry* - 5th edition, by Holland and Rolfe. 1997. Interstate Publishers, Inc., Danville, Illinois.
3. Information presented within the "official" Invitational web site links or Invitational CD for species of trees, insects or diseases. The "official" links are the web pages to which each tree, insect or disease species is linked from the Invitational's web site. Refer to the "Training References" section of the Invitational web site or Invitational CD for the "official" tree, insect and disease training pages and the web site links to each tree, insect or disease species.
4. *National 4-H Forestry Invitational Handbook*. USDA, Extension Service, 50 pp.

Only those species of trees, insects, and diseases listed in Tree Identification, Forest Health -- Insects and Forest Health -- Diseases and Health Indicators will be addressed in bowl questions.

SCORING

The winning team will receive 100 points. The second place team will receive 90 points. Teams that reach the semifinal round will receive 80 points, the round before that 70 points, etc. All teams will receive the points due for competing in the first round, whether or not they advance.

Spectators will be allowed only for the final round of competition, except when authorized by the Management Committee member supervising the Forestry Bowl.

SUGGESTED BOWL SETUP

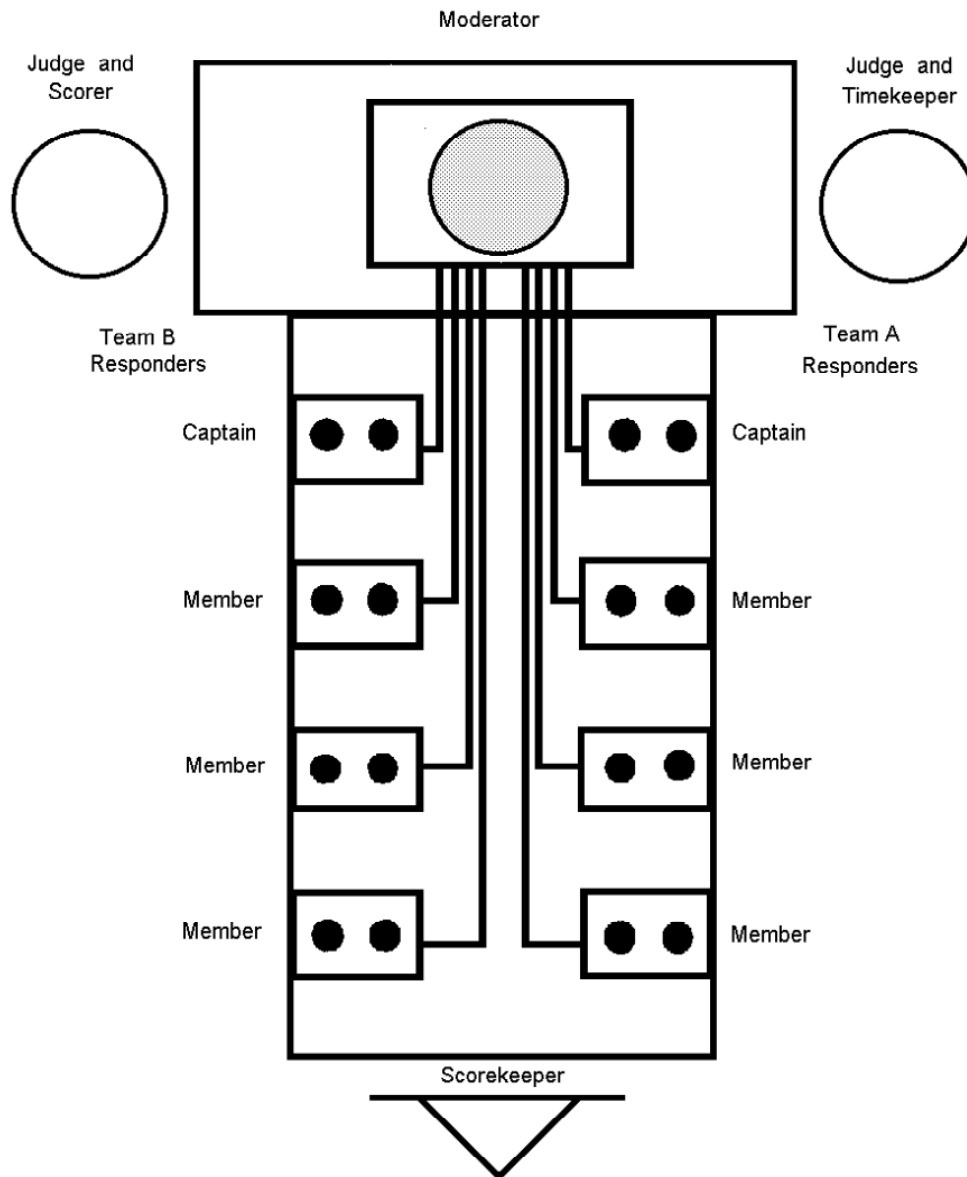

FOREST EVALUATION

Objectives

Teams of four contestants will learn to evaluate site factors and stand factors which effect the growth of forest crops. In addition, they will learn to plan the future management of a forest stand. In order to successfully compete in this event, it is necessary for the participants to carefully study the material in the Forest Evaluation Study Guide, pages 32-37. Each part of the event is closely related to the others so it is very important to gain an understanding of these relationships.

Contest Rules

1. Forestry teams will complete the forest evaluation contest as a group. This is not an individual event.
2. Forest Evaluation is divided into four parts; I. Site Evaluation, II. Forest Stand Evaluation, III. Forest Inventory and IV. Recommended Practices.
3. Competing teams will be given a situation description for the plot designated for the event. This situation description may include information about the landowner, his or her management objectives, local markets for forest products, etc. Teams will be responsible for completing all four parts of Forest Evaluation.
4. Devices and conditions to aid participants in making their decisions may include compass, clinometer, Abney level, tree scale stick, marked plot boundaries, designated trees for Section III. INVENTORY, and a soil pit for Section I. SITE EVALUATION.
5. Seventy-five (75) points are possible for each of parts I, II, III and IV, and a total of 300 points are possible for the entire contest.

For part I categories A, B, C, D and E have a possible value of 15 points each.

For part II categories A, B, C, D, E are each worth 10 points. Part F is worth 25 points.

For part III each correct answer of tree species, crown class, DBH, and height in 16-foot logs is worth 3 points. Board-foot volume per acre and tree value per acre are worth 7.5 points each, provided that they are within $\pm 10\%$ of the correct value.

For part IV each management practice is worth 5 points.

FOREST EVALUATION STUDY GUIDE

Every acre of land should be devoted to its best use. This is an idea that landowners have had about agricultural land for many years. Level and slightly rolling land was used for row crops and grain, and rolling and better upland slopes for pasture and meadow. The general ideas about forest land are that forests will grow well on all lands not suited for other crops. This is not correct. There are excellent, good, fair, and poor sites for timber production just as there are different kinds of farm crop land. There are forest lands that will economically support cultural practices and permanent physical improvements, and other stands in the same area might barely pay land taxes. There are acres that can be harvested every 10 years, and there are other acres that may never produce commercial timber. Forest Evaluation is based on the premise that trees will be harvested, now or in the future, to maximize the goals of a specified landowner.

SITE EVALUATION

The site is the habitat or environment in which a plant or plant community lives. There are a number of site factors that determine the desirability of a particular location for tree species. Some of the factors are soil depth, slope percent, aspect and slope position. These factors can be used to determine the forest land capability class of a particular tract of land.

Soil depth is the distance from the soil surface down to unweathered rock or an impermeable layer which restricts water movement and root penetration. For contest purposes shallow soils are less than 24 inches deep, and deep soils are greater than 24 inches deep.

Slope percent is the number of feet of rise or fall in 100 feet of horizontal distance. For contest purposes slope percent is broken into the following categories: 0-20 percent, 20-40 percent and 40 percent plus. Slope percent can be measured with an Abney level or a clinometer. Figure 7 below illustrates a 24 percent slope.

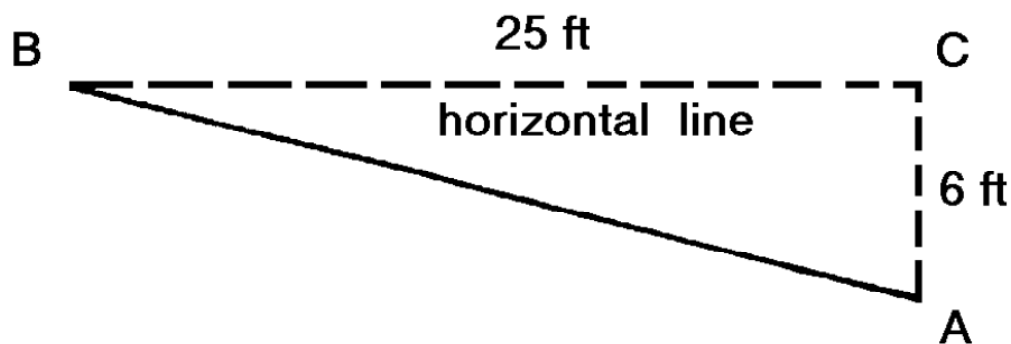

$$\begin{aligned} AC / BC \times 100 &= \text{slope percent of AB} \\ 6 / 25 \times 100 &= 24 \text{ percent} \end{aligned}$$

Figure 7. Method of determining slope percent.

Aspect is determined by taking a compass reading while facing down a slope. The direction water would run gives the compass direction. Any slope facing north and east of a line extending from northwest (315E) to southeast (135E) is considered to have a desirable northeast aspect. Any slope facing south and west of the same line is considered to have a less desirable southwest aspect. See figure 8, below.

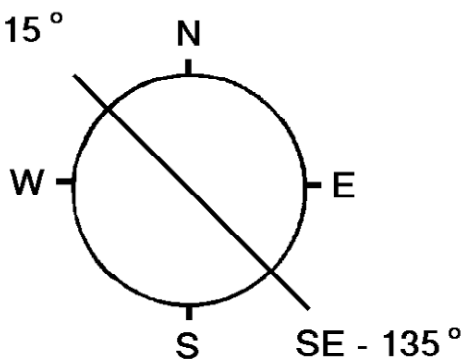

Figure 8. Method of determining aspect.

Slope position is determined only on hilly sites. The positions are classified as upper 1/3, middle 1/3 and lower 1/3. Ridge tops or level plateaus and bottomlands are classified separately in land capability.

Forest land capability classes are described below for the purpose of this contest:

Class I. Excellent has few limitations for tree growth. Most sites have little slope and no erosion problems. The soil is fertile and holds water well. It is well drained, but not droughty. These site will produce timber well.

Class II. Good is usually gently sloping. In some cases there are drainage problems that affect tree growth.

Class III. Fair may be fairly steep. Soils may have low fertility and tend to be droughty.

Class IV. Poor may be very steep with shallow soil. Sites may be rocky, shaly, have low fertility and be very dry.

FOREST STAND EVALUATION

Grazing damage is defined by the following categories for the purpose of this contest

Grazed - tree seedlings eaten or trampled, soil compacted, and bark rubbed off

Ungrazed - no evidence of grazing damage.

Fire may be present as a destructive agent or a management tool. **Wildfire** can be very destructive particularly in hardwood forests. Destruction of the litter layer on the forest floor, crown scorch or burning of the foliage, and scalds or scars on the tree trunks are all evidence of wildfire damage.

Prescribed fire or controlled burn is a management tool which can be used to manage competing vegetation, prevent fuel accumulation, and improve wildlife habitat without damaging crop trees.

Size distribution is classified into 4 categories for the purposes of this contest. **In some stands more than one size class may be represented, particularly in uneven-aged stands. To determine the size class of the stand evaluate the trees that make up the overstory or main forest canopy of the plot.** Specific size classes are defined as follows: trees less than 1 inch in diameter – **seedlings**; trees from 1 to 3 inches in diameter – saplings; trees 4 to 10 inches in diameter – poles; and trees more than 10 inches – sawtimber (each measured at DBH).

Forest types are different from each other in species composition and management requirements. The following forest types, defined by the Society of American Foresters in *Forest Cover Types of North America*, are used in this contest:

Hard Pines (Type 77, Shortleaf Pine – Virginia Pine)

Dominant species – shortleaf pine and Virginia pine

Associated species – pitch pine, various oaks and hickories

Mixed Oaks (Type 53, White Oak; and Type 55, Northern Red Oak)

Dominant species – white oak and northern red oak

Associated species – black oak, scarlet oak, chestnut oak, white ash and yellow-poplar

White Pine (Type 21 – White Pine)

Dominant species – eastern white pine

Associated species – yellow-poplar, eastern hemlock, oaks, birches, black cherry, white ash, sugar maple, American basswood, shortleaf pine and pitch pine

Cove Hardwoods (Type 57, Yellow-poplar; Type 58, Yellow-poplar – Hemlock)

Dominant species – yellow-poplar

Associated species – eastern hemlock, black locust, red maple, sugar maple, sweet birch, oaks, cucumbertree, American basswood, blackgum and white ash

Red Oak, White Oak, Hickory (Type 52, White Oak, Red Oak, Hickory)

Dominant species – northern red oak, white oak, black oak and hickories

Associated species – a wide variety of hardwood species

Northern Hardwoods (Type 25, Sugar Maple-Beech-Yellow Birch; Type 60, Beech-Sugar Maple)

Dominant species – American beech, sugar maple, (yellow birch - absent at Jackson's Mill)

Associated species – American basswood, red maple, eastern hemlock, white oak, northern red oak, white ash, black cherry, mockernut hickory, sweet birch, yellow-poplar, cucumbertree, black walnut

Stand origin can vary from one stand to another, even though the stands are of the same forest type and size distribution. Timber stands may originate by several different means. Natural stands may arise from **seedlings, sprouts** or a **mixture** of both. Sprouts, also known as coppice, can be from either cut stumps or root suckers. Sprouts are important sources of new trees in the regeneration of most hardwood forests. Stands which originate from planted seedlings are called **plantations**. These stands may be of higher quality than their predecessors if genetically improved seeds or seedlings are used.

Stocking is a term used to describe how well the trees in a stand utilize the available space. Stocking, for the purposes of this contest, is measured using the average diameter of all trees 10 inches dbh and larger, and the number of trees per acre 10 inches dbh and larger. Figure 9 is used to determine stocking. A **well-stocked** stand is one in which the trees are well distributed, and all the space is utilized, but the trees still have room to grow. An **understocked stand** is one in which there are open spaces between the trees so that the stand will not produce its full potential. An **overstocked stand** is one which is so crowded that trees are growing very slowly, and some may be dying because of too much competition.

For example: If the plot size is 1/10 acre, average dbh of trees 10 inches dbh and larger is 16 inches and the number of trees in the plot 10 inches dbh and larger is 12, is the stand understocked, well-stocked or overstocked? If there are 12 trees in a 1/10 acre plot there are 120 trees per acre. Look at the Stocking Guide (Figure 9) and find 120 trees per acre on the Y-axis. Now find 16 inches dbh on the X-axis. Extend the trees per acre horizontally toward the right and the dbh vertically toward the top until they intersect. The point of intersection falls in the part of the Stocking Guide labeled “overstocked.” This means the plot is overstocked.

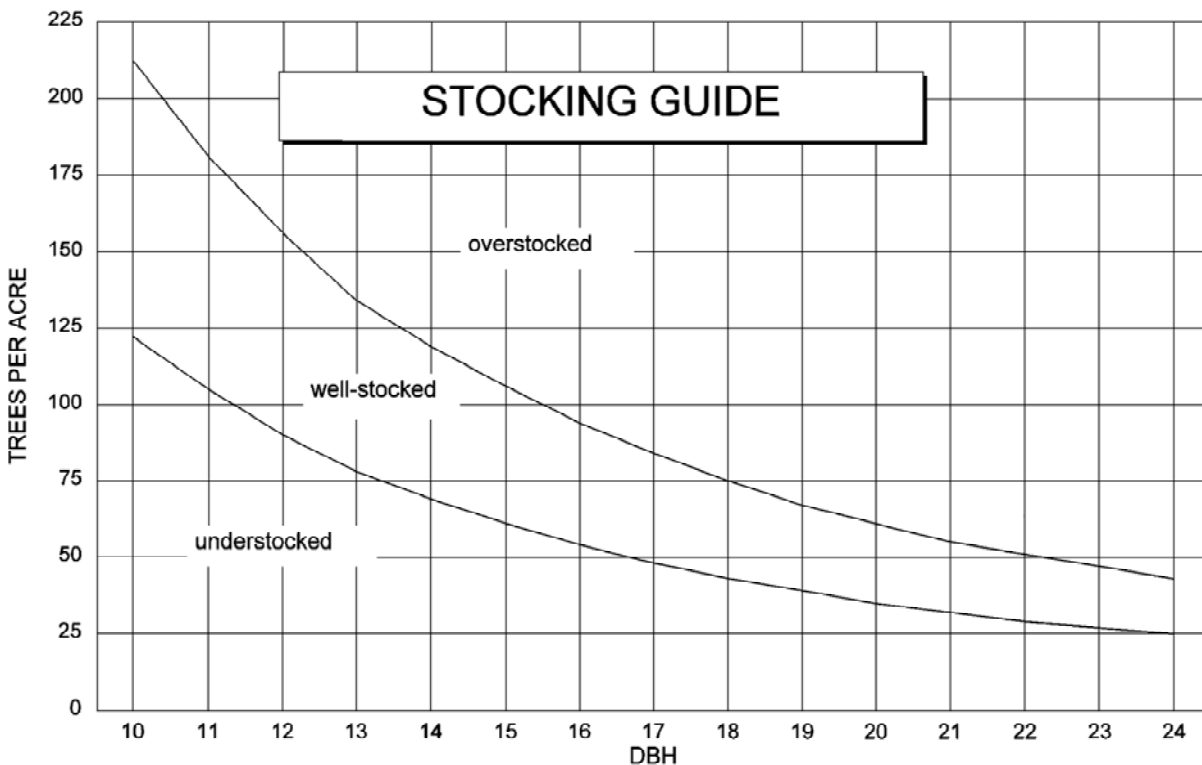

Figure 9. Method of determining stocking.

FOREST INVENTORY

Species of each numbered tree should be listed using the common names from the Official Tree List on pages 5-7.

Crown class of each tree should be determined and recorded as either dominant, co-dominant, intermediate, or suppressed. These crown classes are defined in the Glossary on page 44.

DBH(diameter at breast height) of each tree should be measured and recorded to the nearest even 2-inch diameter class (see page 15).

Height (in 16-foot logs) of each tree should be measured and recorded to the nearest full half-log.

Board-foot volume per acre – The board-foot volume of each tree should be determined and recorded using the table on page 17. Then, after taking into account the plot size, the board-foot volume per acre should be calculated.

Tree value per acre – The dollar value of each tree should be determined by multiplying the volume of each tree, expressed in thousand board feet, by the value of that species per thousand board feet. Values for each species will be given in the written situation description. For example: if a 20 inch, 2½ log white oak contains 348 board feet, and white oak sells for \$300 per thousand board feet, then the value of the tree equals $\$300 \times 0.348 = \104.40 . Then, after taking into account the plot size, the tree value per acre should be calculated.

RECOMMENDED PRACTICES

A list of forest management practices appears on the Forest Evaluation Score Sheet. Each team will be given **a written scenario** with information about the landowner and his or her objectives for management. Based on the data you collected about the site and forest stand, and on the landowner's management objectives, consider each practice listed on the score sheet. Mark the practices you recommend. The practices recommended should be those which will improve the stand and help accomplish the landowner's objectives.

Sample Scenario – Henrik and Dolores Svensen are a couple in their late forties. Their twins will be starting college next fall and they are looking to the 40 acre woodlot to supply them with some cash to help pay for some of the college expenses. Henrik enjoys hunting deer and turkey on his property and often invites one or two friends to hunt with him. They would not want any activity in their woods to damage the wildlife habitat. They have owned the woodlot for about 20 years and have managed it diligently over that time. They have a Stewardship plan that was drawn up right after they purchased the property and it has been updated once since then. Local markets are good with red oak worth \$300, white oak worth \$250, and mixed hardwoods worth \$200 per thousand board feet on the stump. After your inventory and observation of their woodlot what recommendations would you make that would help them meet their objectives at this time?

Thinnings - are partial cuttings in even-aged timber stands. They are designed to improve future growth by regulating stand density. Thinnings can be commercial, where some or all of the wood harvested is put to use, or precommercial, where no wood is utilized.

Salvage or Sanitation Harvests - are cuttings by which the dead, dying, damaged, or deteriorating trees are removed to prevent the spread of pests as well as putting this "at risk" wood to use.

Selection Harvest - is a regeneration method used in uneven-aged stands, or to create uneven-aged stands, in which individual trees or groups of trees are removed. Some trees in each age class are removed including mature trees, poorly-formed trees, and trees of undesirable species.

Shelterwood or Seed Tree Harvests - are regeneration methods designed to create an even-aged timber stand. These harvests remove the mature stand leaving only a few trees for seed or to shelter the new stand.

Clearcutting - a regeneration method that involves the removal of the entire stand in one cutting to create an even-aged stand. Regeneration is provided for naturally, where desirable tree species seedlings or seed exists, or artificially through planting, where conversion to a more desirable species is recommended.

Prescribed Burning - is generally used as a means of controlling hardwood vegetation in softwood stands. Prescribed burning also improves wildlife habitat, stimulates sprouting seed germination, and encourages the growth of herbaceous plants.

Wildlife Habitat Improvement - Wildlife will generally coexist with any forest management scenario but the type of wildlife will vary depending on the management system a forester employs. Most wildlife species prefer a varied landscape with many edge and riparian zones. The type of wildlife a forester manages for is largely dependent on landowner objectives but also the type of forest a particular site will support

Recreational Opportunities - Recreation often goes hand-in-hand with forest management. Hiking, hunting, fishing, cross-country skiing, ATV riding, mountain biking, and bird watching are only a few of the types of recreation for which a forester might manage a forest. The ultimate decision should be largely based on the objectives of the landowner.

Non-Timber Forest Products - This area of forest management can work simultaneously with other forest management practices and is more developed in some regions of the United States such as the Pacific Northwest. It may be a hobby for some landowners yet can also generate a significant cash income for other landowners. Such things as Ginseng, St. John's Wort, and a whole host of mushroom species are items that a forester should be aware of and could be managing for given proper site conditions.

FOREST EVALUATION SCORE SHEET

State _____

Total Score _____

I. SITE EVALUATION: Circle (A) Soil Depth, (B) Slope Percent, (C) Aspect, and (D) Slope Position as they apply to the area.

A. Depth of Soil	Deep - 24" or more						Shallow - less than 24"					
B. Slope Percent	Rolling 0-20%		Steep 21-40%		Very Steep 41%+		Rolling 0-20%		Steep 21-40%		Very Steep 41%+	
	NE	SW	NE	SW	NE	SW	NE	SW	NE	SW	NE	SW
D. Slope Position												
Bottom	I	II	I	II	I	II	I	II	I	III	II	III
Lower 1/3	I	II	I	II	I	III	I	III	II	III	III	IV
Middle 1/3	I	II	II	III	II	III	II	III	III	IV	IV	IV
Upper 1/3	II	III	III	III	IV	IV	III	IV	III	IV	IV	IV

E. Forest Land Capability Class: Determine the proper class by drawing a line down from the **Aspect** circled and across from the **Slope Position** circled. The Roman numeral where these lines intersect indicates the class. **Circle the class below.**

I. Excellent II. Good III. Fair IV. Poor

Part I Score _____

II. FOREST STAND EVALUATION: (Check the correct answer in each section A-F).

A. Grazing Damage

Grazed _____
 Ungrazed _____

D. Forest Type

Hard Pines _____
 Mixed Oaks _____
 White Pine _____
 Cove Hardwoods _____
 Red Oak, White Oak, Hickory _____
 Northern Hardwoods _____

E. Stand Origin

Seedling _____
 Sprout _____
 Mixed _____
 Plantation _____

B. Fire

Unburned _____
 Wildfire _____
 Prescribed Fire _____

F. Stocking

Under stocked _____
 Over stocked _____
 Well stocked _____

C. Size Distribution: (There may be more than one answer)

Seedlings _____ Saplings _____ Poles _____ Sawtimber _____

Plot size _____

Part II Score _____

III. FOREST INVENTORY

Plot Size _____

Tree Number	Tree Species (3 points)	Crown Class (3 pts)	DBH (3 pts)	Height in 16 ft Logs (3 points)	Board-foot Volume	Tree Value
1						
2						
3						
4						
5						
Total Board Foot Volume and Tree Value in Plot						
Per acre values (7.5 points each)						

Crown Class: D = dominant, C = co-dominant,
I = intermediate, and S = suppressed

Part III Score _____

IV. PRACTICES RECOMMENDED: (Mark those practices you recommend.)

- 10. Which species (1 or more) would you favor on this site? _____
- 11. Protect the area from wildfire. Report any fire to the state forestry agency _____
- 12. Clearcut the stand and plant with a desirable species _____
- 13. Conduct a shelterwood or seed-tree harvest _____
- 14. Use Best Management Practices such as seeding landings and haul roads, installing waterbars to prevent erosion, leaving buffer strips along streams, minimizing stream crossings, and abiding by the Sustainable Forestry Guidelines _____
- 15. Manage stand for non-timber forest products _____
- 16. Conduct a selection harvest _____
- 17. Manage stand for wildlife habitat improvement _____
- 18. Stand is not yet merchantable, leave alone to grow _____
- 19. Conduct a prescribed burn _____
- 20. Clearcut the stand and allow for natural regeneration _____
- 21. Manage stand for recreational opportunities _____
- 22. Conduct a salvage or sanitation cutting _____
- 23. Conduct a thinning _____
- 24. Fence the area from livestock _____

Part IV Score _____

FORESTRY WRITTEN EXAMINATION

Objective

Contestants will be given an opportunity to demonstrate their knowledge and understanding of forestry information by completing a written examination. The examination will cover a broad spectrum of subject matter similar to the Forestry Bowl but will allow for more detailed questions since contestants will get to read them.

Contest Rules

1. The examination will be an individual event with the score contributing to each individual participant's score and the team score. A maximum of 50 points is possible.
2. The examination may include multiple choice, fill-in-the-blank, matching and discussion questions. One hour will be allowed for completion.
3. Discussion questions will be drawn from the following subject areas: forest management practices, forest health, forest regeneration, forest harvesting, and forests and society.
4. Study references will be the same as for the Forestry Bowl. See page 29.

SCORING METHOD FOR INDIVIDUAL AND TEAM COMPETITION

Individual and team scores for the National 4-H Forestry Invitational are determined by the method illustrated in the table below. Remember, a team may be made up of three or four members; but only the top three in each individual category and the two team events count toward the total team score.

<u>Event Categories</u>	-----Total Possible Points----- Individual Member Scores				<u>Team</u>
	<u>A</u>	<u>B</u>	<u>C</u>	<u>D</u>	<u>Scores</u>
Tree Identification	100	100	100	100	300
Tree Measurement	100	100	100	100	300
Compass and Pacing	100	100	100	100	300
Topographic Map Contest	50	50	50	50	150
Forest Health -- Insects	50	50	50	50	150
Forest Health -- Diseases and Health Indicators	50	50	50	50	150
Forestry Written Examination	50	50	50	50	150
Forestry Bowl	----	----	----	----	100
Forest Evaluation	----	----	----	----	300
TOTALS	500	500	500	500	1900

The maximum score an individual contestant may achieve is 500 points, and the maximum team score is 1900 points.

FOREST UNDERSTANDINGS AND FACTS

The following concepts and facts cover the broad range of forestry. An understanding of each statement will benefit resource managers, well rounded citizens, and forestry team members. Some are so logical or simple that they may be taken for granted and overlooked.

Characteristics, Distribution, and Status of Forest Resources

1. Trees have distinctive characteristics by which they can be identified.
2. Trees depend upon water, soil nutrients, sunlight, and air for growth.
3. Climate, soil, and topography influence the natural range and distribution of the different types of forest communities.
4. Forest communities influence their climate and their soil.
5. Forest litter, humus, and roots give forest soils an exceptional ability to absorb moisture and resist erosion.
6. In the forest some organisms are adapted to living in the forest soil, some on the forest floor, some in the undergrowth, and some in trees.
7. Forests are constantly undergoing change, and as they mature and are harvested or die, some species of plants and animals may be replaced by others.
8. The interrelationships among the plant and animal members of forest communities and their environments determine the characteristics of a particular forest.
 - a. Each plant and animal in a forest community influence that community.
 - b. Forest communities influence the plants and animals of which they are composed.
9. Fires, diseases, insects, man, and animals may be harmful or beneficial to the forest.
10. Some lands are better adapted for the growing of forests than for other uses.
11. Forests have certain characteristics which make them attractive for recreational activities.
12. An expanding population and new uses for forest products and services make necessary more intensive multiple purpose management of forest resources.

Understanding the Uses of Forest Resources and Their Importance to Man

1. The original forests of the nation were primary sources of building the nation.
2. Forests yield many essential products for man's use.
3. Many communities are highly dependent upon local forests, forest industries, and forest recreation for economic stability.
4. New uses for the products of the forest are being discovered through research and development.
5. Forests provide a wide variety of recreational opportunities.
6. Forests are important in helping to protect watershed from floods and droughts.

Understanding Problems and Techniques of Management

1. Forests can be managed to produce a continuous supply of wood and wood products, wildlife, water, and recreational opportunity.
2. Foresters use various practices in managing forest resources:
 - a. Insects and disease control
 - b. Fire control
 - c. Harvesting practices
 - d. Thinning and pruning operations
 - e. Reforestation
3. Volume and growth data are essential in determining management practices necessary to produce the optimum amount of forest products.
4. Research is essential for the development of new and improved forest management practices and the more efficient utilization of forest products and services.

Understanding Policy and Administrative Techniques

1. Public use of forest land carries an obligation for good citizenship.
2. Small woodland owners control a major portion of commercial forest lands which are a potential source of larger quantities of forest products and services.
3. The woodland owner can obtain technical advice and assistance in forest management from many public and private organizations and agencies.

4. Current state and federal programs provide financial assistance as incentives for better management of forest resources.
5. Many progressive public and private owners of forest lands are managing forests for multiple uses rather than solely for timber production.
6. Forest owners have responsibilities as well as rights in the management and use of forests under democratic living.
7. Cooperation between public agencies, private owners, and the general public is necessary in protecting forests against fires, diseases, insects, and excessive animal populations.
8. Policy decisions must be made to settle differences of opinion which arise from competing uses of the forests.

Forestry Facts

1. America's forests cover about 737 million acres, or 32% of the nation's land area.
2. America's forests still cover about 70% of the area they covered when the Pilgrims landed in 1620.
3. Private individuals own about 59% of the U.S. forest land base; local, state and federal governments own about 27%; and the forest products industry owns about 14%.
4. Growth rates exceed harvest rates in America's forests by a wide margin. In 1992 net growth was 21.6 billion cubic feet and harvest was only 16.3 billion cubic feet.
5. More than 244 million acres, about 33% of America's forests, are preserved in wilderness areas, national parks, wildlife refuges, and other parks and preserves where no commercial activity is permitted.
6. The U.S. is a net importer of most raw materials used to sustain the domestic economy, including wood and wood products.
7. The U.S. population is presently growing at the rate of 1% each year. If this rate is sustained the population will double in less than 100 years.
8. The per-person use of wood in the U.S. is about 80 cubic feet each year, an increase of more than 30% since 1970.
9. Wood is the only natural resource on earth that is at once renewable, recyclable, reusable, and biodegradable.
10. The energy required to grow our wood supply is free. It comes from the Sun.

GLOSSARY

Abney Level - An instrument used to determine the percent of slope of a site.

Aspect - A compass reading taken facing down a slope in the direction water would run, give the compass direction of a slope.

Best Management Practices (BMPs) - A practice or combination of practices, that is determined by a state to be the most effective, practicable means of preventing or reducing the amount of pollution generated by nonpoint sources (such as managed forests) to a level compatible with water quality goals.

Clinometer - Height measuring device.

Conservation - Gifford Pinchot, a turn of the century forester closely associated with President Teddy Roosevelt, applied the word to describe a natural resource philosophy. It meant "wise use." Through the years it has taken on an extended meaning that really says "wise use over a period of time." The time factor forces us to consider the consequences of current use compared to future use.

Coppice - A stand of forest originating from the stumps or roots of trees previously cut. Most hardwood species sprout readily when cut young. Very few conifers will sprout from the stump.

Crown Class - Tree crowns are classified as to the position in which they are found. The following are the main generally recognized classes:

Dominant - Trees with crowns that extend above the average of the tree crowns and receives light from directly above and some from the sides.

Co-Dominant - Trees with crowns that form the general level of the crown cover and receive full light from the top, but very little from the sides.

Intermediate - Trees that are shorter than the two preceding classes but with some branches extending into the general crown cover. Receives little light from above and none from the sides.

Suppressed - Trees with crown entirely below the general crown level and receiving no direct light either from above or below.

Cull - Tree or log of merchantable size, but no market value.

DBH - Diameter of a tree at breast height or 4 1/2 feet above ground.

Duff - Often referred to as litter which is made up of materials of the upper layer of the forest floor. This includes freshly fallen leaves, twigs and slightly decomposed organic matter.

Erosion - The wearing away of the soil and minerals by climatic agents such as wind and water.

Exposure - That portion of the slope that is directly in the path of wind, rain, sun. That part of a slope open to action of the elements.

Forest Land Capabilities - The productivity of the land as it is affected by particular location or position on a slope.

Forest Types - A classification of species indicating the majority of the species represented in an area.

Germination - This process occurs when viable seed meet favorable conditions that will allow it to grow.

Girdle - To chop or remove a strip of bark or a section of wood containing the food-carrying tissue of a tree in an even strip from the perimeter of the tree or twig.

Harvest - The removal of marketable products from the forest.

Mature Tree - A tree that has reached a maximum growth that the forest manager decides is a merchantable product.

Multiple-Land-Use - A term used to indicate the management of timber wildlife and recreation in an integral, consolidated program.

Merchantable Height - A term used to indicate the marketable length of a tree.

National Forests - These differ from National Parks in that recreation is not their only use. Recreation may be a primary use in some part of the national forest. For example, there are more acres of Wilderness areas in national forests than national parks. The national forest system administers 154 forests and 19 grasslands. On most national forest land timber, water, wildlife, recreation, and grazing are compatible resources. These are managed for productive and sustained yields according to the land's capability.

National Parks - The National Park Service was established by Congress to promote and regulate the use of national parks, monuments, and reservations and to conserve the scenery and the natural and historic objects and the wildlife therein. The Park Service administers 295 separate areas. The Service manages some areas for historical or recreational uses. Each of the 35 national parks was established to preserve a unique natural area for our enjoyment and study. National Parks are confused with national forests.

Old Growth - This term describes eastern forests and virgin western forests with trees over 100 years of age.

Partial Cut - Method of cutting mature trees such as shelterwood cut, selection cut, or seed tree cut.

Pole Timber - Trees 4 to 10 inches in diameter at DBH

Prescribed Burn - Controlled burning to enhance forest management techniques in silviculture, wildlife management, fire hazard control, etc.

Preservation - In natural resources, other than wood preservation, this term is related to land use. The meaning stems from 19th century land reserves wherein areas and resources were set aside for limited or restricted use and development. Preservation often restricts land to recreation or scientific study. Preservation may be contrasted to the principle of multiple use which rather intensively develops one or more of an area's resources.

Reproduction - **Trees grown from seed and sprout origin**, less than 1 inch in diameter

Residual Stand - That portion of trees left after any partial cut.

Sanitation Cutting - The removal of dead, damaged or susceptible trees; essentially to prevent the spread of pests or pathogens and so promote forest hygiene.

Sapling - Trees from 1 to 3 inches in diameter at DBH

Saw timber - Trees more than 10 inches in diameter at DBH

Seedling - A tree grown from seed; **used to define a young tree before it reaches sapling size, less than 1" in diameter at DBH.**

Silviculture - A term used to indicate the establishment, development, care, and reproduction of stands of timber.

Site - The combination of biotic, climatic, and soil conditions with the ecological factors of an area to produce forests or other vegetation.

Slope Position - A particular location on a slope as upper, middle, or lower slope; ridge top; or bottom land. A specific topographic location.

Sprout - A tree originating from a root or stump.

Stocking - A measure of the proportion of the area actually occupied by trees.

Streamside Management Zone (SMZ) - A strip of land adjacent to a water body or stream channel where soils, organic matter and vegetation are managed to protect the physical, chemical and biological integrity of surface water adjacent to and downstream from forestry operations. An SMZ also may be called a "filter strip" or "buffer zone."

Sustainable Forestry Initiative (SFI) - A comprehensive program of forestry and conservation practices designed to ensure that future generations of Americans will have the same abundant forests and wildlife that we enjoy today. SFI is sponsored by the American Forest & Paper Association (AF&PA). AF&PA member companies have agreed to use sustainable forestry practices on the forestland they manage and to promote sustainable forestry on the forestlands of others.

Sustained Yield - Management of a forest stand to provide a constant supply of timber and revenue.

Timber Stand Improvement (TSI) - Any practice designed to improve a stand of timber by removal of vines, culls, and undesirable species.

Wilderness - In the strictest sense, this means that an area that has never been developed by man. A 1964 Wilderness Act defined it thus: "A Wilderness, in contrast with those areas where man and his own works dominated landscape, is hereby recognized as an area where the earth and its community of life are untrammelled by man, where man himself is a visitor and does not remain." In common use the word is associated with these undeveloped areas and those set aside with a little development. In some cases man-made items are dismantled to reduce the area to a primitive state. Under these broader uses some roadless areas are considered wilderness when the access is limited to hiking, canoeing, or horse back riding and the use is set aside for recreation. To most of the general public, wilderness experiences are gained in a number of settings involving wild but not necessarily true Wilderness areas.

Wild Fire - Fires burning out of control regardless of how or why they were started.

Wolf Tree - A tree that occupies more than its fair share of growing space.

A SUMMARY OF FEDERAL LAWS AFFECTING FORESTRY

Laws form the legal basis for using and managing our nation's forests. Since 1890, more than 140 laws affecting forestry have been passed by the United States Congress and signed by the President. In the early years most laws enabled or authorized the protection and management of the nation's forests. Many of the laws passed in recent years restrict or regulate the use and management of these forests. Some of the more important Federal laws are described below:

Creative Act of 1891 -- Authorized the President of the United States to set aside public lands bearing forests as public reservations commonly called *Forest Reserves*.

Organic Administration Act of 1897 -- Provided that the Forest Reserves, later to be called *National Forests*, were established to improve and protect the forest, to secure favorable conditions of water flow, and to furnish a continuous supply of timber.

Transfer Act of 1905 -- Transferred the administration of the Forest Reserves from the United States Department of the Interior to the United States Department of Agriculture.

Twenty-five Percent Fund Act of 1908 -- Established the procedure for paying the states twenty-five percent of the monies received from national forest timber sales to benefit public schools and public roads in counties where national forests are located. These payments are made in lieu of taxes.

Weeks Law of 1911 -- Authorized purchasing and adding to the National Forest System forested, cut-over, or denuded lands within the watersheds of navigable streams which are necessary to regulate the flow of navigable streams or to produce timber.

Smith-Lever Act of 1914 -- Established a Federal-State Cooperative Extension program to provide education for the public in agriculture and natural resources.

Clarke-McNary Act of 1924 -- Authorized technical and financial assistance to the states for forest fire control and for production and distribution of forest tree seedlings. (Sections 1 through 4 were repealed by the Cooperative Forestry Assistance Act of 1978.)

McSweeney-McNary Act of 1928 -- Authorized a comprehensive Forest Service research program. (This act was repealed and supplanted by the Forest and Rangeland Renewable Resources Research Act of 1978.)

Multiple Use - Sustained Yield Act of 1960 -- Established a policy of multiple use, sustained yield management for the renewable resources of the National Forest System.

McIntyre-Stennis Act of 1962 -- Established a cooperative forestry research program for state land-grant colleges and universities.

Clean Air Act of 1963 -- Gave the Federal government enforcement powers regarding air pollution for the first time. This act and subsequent amendments impact the forest industry by affecting prescribed burning for forest management and emissions from forest products manufacturing plants.

Wilderness Act of 1964 -- Established the National Wilderness Preservation System by setting aside sections of federal forest land as wilderness.

National Environmental Policy Act of 1969 -- Required that environmental considerations be incorporated into all Federal policies and activities, and that all Federal agencies prepare environmental impact statements for any actions significantly affecting the environment.

Federal Water Pollution Control Act Amendments of 1972 -- Established as a national objective restoring and maintaining the chemical, physical, and biological integrity of the nation's water and required area wide planning to prevent future water pollution that could be associated with growth, development, and land use, including timber management.

Endangered Species Act of 1973 -- Provided for the protection and conservation of threatened and endangered fish, wildlife, and plant species. Directs all Federal agencies to utilize their authorities and programs to further the purpose of the act.

National Forest Management Act of 1976 -- Established additional standards and guidelines for managing the national forests, including directives for national forest land management planning and public participation.

Cooperative Forestry Assistance Act of 1978 -- Authorized the Secretary of Agriculture to work in cooperation with State Foresters in nine cooperative forestry assistance programs. Among these programs is the *Forestry Incentives Program*, a federal cost-share program designed to encourage the management of private forest lands.

Renewable Resources Extension Act of 1978 -- Authorized expanding the forest and rangeland renewable resources portion of the extension education program.

Forest and Rangeland Renewable Resources Research Act of 1978 -- Authorized expanding forest and rangeland renewable resources research.

Reforestation Tax Incentives (part of the Recreational Boating Safety and Facilities Improvement Act of 1980) -- Provided tax credits and deductions for landowners who reforest their property, as an incentive to encourage reforestation.

Food Security Act of 1985 (1985 Farm Bill) -- Established the *Conservation Reserve Program*. The program was designed conserve 40 to 45 million acres of highly erodible cropland by paying landowners to plant permanent vegetative cover, such as grass or trees, and maintain that vegetative cover for 10 years.

Food, Agriculture, Conservation, and Trade Act of 1990 (1990 Farm Bill) -- Established the *Forest Stewardship Program*, a program designed to encourage multiple resource forest management on nonindustrial private forest lands. A companion program, the *Stewardship Incentives Program*, was designed to provide cost-share assistance funding to encourage the implementation of management practices.

Coastal Zone Act Reauthorization Amendments of 1990 -- Required that states with Coastal Zone Management Programs develop and implement Coastal Nonpoint Pollution Control Programs to control sources of nonpoint pollution (including managed forests) which impact coastal water quality.

SUGGESTED REFERENCES

1. *Forestry Handbook*. SAF, 1989. Jules Kazimir, Dept. 8-0318, Wiley- Interscience, A Division of John Wiley & Sons, Inc., 605 Third Avenue, New York, New York 10158. Price--\$54.95
2. *Important Trees of the Eastern United States*. FS-466. October 1991. USDA FS 112pp. (Available from the USDA Forest Service or your State Forester.)
3. *Know Your Trees*. Identification Book of the American Forestry Association. American Forestry Association, 1319 Eighteenth Street N.W., Washington, D.C. 20036. 374 pp.
4. *The Stewardship of Northern Hardwoods: A Forest Owner's Handbook*. 1995. State University of New York, College of Environmental Science and Forestry, 1 Forestry Drive, Syracuse, NY 13210.

FORESTRY BOWL AND WRITTEN EXAM REFERENCES

1. National 4-H Forestry Manuals - Units A, B, and C; available from the "Training References" section of the Invitational web site.
2. *Forests and Forestry* - 5th edition, by Holland and Rolfe. 1997. Interstate Publishers, Inc., Danville, Illinois.
3. Information presented within the "official" Invitational web site links or Invitational CD for species of trees, insects or diseases. The "official" links are the web pages to which each tree, insect or disease species is linked from the Invitational's web site. Refer to the "Training References" section of the Invitational web site or Invitational CD for the "official" tree, insect and disease training pages and the web site links to each tree, insect or disease species.
4. *National 4-H Forestry Invitational Handbook*. USDA, Extension Service, 50 pp.